

Arctic LTER Proposal

RESULTS OF PRIOR SUPPORT, PUBLICATIONS, DATA SETS

- [RESULTS OF PRIOR SUPPORT](#)
- [PUBLICATIONS FROM 1992 TO 1998](#)
- [DATA SETS ON THE ARCTIC LTER DATABASE](#)

[THEME, CONCEPTUAL FRAMEWORK, RESEARCH](#)

REGIONALIZATION, SYNTHESIS

- [THE NEW THEME OF PREDICTING FUTURE ECOLOGICAL CHANGE](#)
- [CONCEPTUAL FRAMEWORK OF THE ARCTIC LTER SITE](#)
- [TERRESTRIAL](#)
- [STREAMS](#)
- [LAKES](#)
- [LAND-WATER RESEARCH](#)
- [REGIONALIZATION AND CROSS-SITE ACTIVITIES](#)
- [SYNTHESIZING RESEARCH: LINKAGES WITHIN THE ARCTIC LTER: CONTRIBUTIONS TO BROADER ECOLOGICAL ISSUES](#)

[LITERATURE CITED](#)

RESULTS OF PRIOR SUPPORT, PUBLICATIONS, DATA SETS

A. Results of Prior Support

Site Description. The Arctic LTER site is the tundra, lakes, and streams near Toolik Lake, Alaska (68°N and 149°W) in the northern foothills of the Brooks Range some 180 km south of the Arctic Ocean ([Fig. 1](#)). Temperatures average -8.4°C annually while summer temperatures average 0.6, 8.1, 11.9, and 7.4°C for May through August. Glaciated low rolling hills are covered with sedges and grasses dominated by cotton grass mixed with dwarf birch, low willows, and forbs. Moose and herds of caribou frequently move through the site and wolves and grizzly bears are present. The underlying permafrost insures that the soils are moist despite the low 200-300 mm total precipitation. Streams and small lakes are abundant; the 4th order Kuparuk River and the 1 km² Toolik Lake (d_{max} 25 m) are the largest. The growing and runoff season begins in late May, lakes thaw in mid to late June, and lakes and soils freeze in late September. Streams and lakes are phosphorus limited while the tundra plants are nitrogen limited. All parts of the system are oligotrophic. Details of the site are at www.mbl.edu/html/ECOSYSTEMS/lterhtml/arc.html.

Research History. The site was chosen in 1975 when the gravel road along the Trans-Alaska Pipeline opened access to a transect of coastal plain, foothill, and mountain tundras, streams, and lakes. A foothills site was chosen because shallow lakes and coastal

wet tundra at Barrow had been well-studied in a 4 year intensive project of the IBP (Brown et al. 1980, Hobbie 1980). The history of Toolik Lake research is described by Hobbie (1997), O'Brien et al. (1997), Hershey et al. (1997), and Shaver (1998, in the electronic atlas of the region). Briefly, *in the first few years* we described the environment and the rates of ecological processes; this included the plants, animals, chemistry, and physics as well as rates of productivity, predation, and decomposition in the various types of tundra, streams, and lakes. *In the next phase of research*, the monitoring of the environment continued but we added studies of the controls of biotic productivity, abundance, and diversity in small experiments such as nutrient additions to plots and plankton samples, predator exclusion cages on lake sediments, and planktonic mesocosms. *In the first LTER project, 1987-1991*, we began long-term climate measurements and a series of long-term and large-scale experimental manipulations to examine controls of processes as well as responses of whole systems to changes that included additional nutrients in tundra, streams, and lakes, increases in air temperature, and changes in the top predators of lake ecosystems. *During the 2nd LTER funding cycle, 1992-1998*, the monitoring and large-scale experiments continued and we added GIS and simulation modeling of carbon and nitrogen cycles in tundra, streams, and lakes. Studies of land-water transfers of material began and the overall viewpoint changed slightly from concentration on a single patch of tundra, stream, or lake to a larger perspective which considered the effect of variability across the arctic landscape.

Overview of Major Achievements of the Arctic LTER. These include: a process-based understanding of the ecology of the whole system of tundra, streams, and lakes; a record of current ecological variability and long-term change; long-term experimental manipulations; pioneering use of stable isotopes in whole-system additions; models of carbon cycle in tundra, of nitrogen cycling in streams, and of lake physics and carbon cycling, a large data base accessible on the WWW; education of graduate and undergraduate students; export of our knowledge through comparative studies with other LTER sites; and attraction of many other projects to the site.

Goals of Previous LTER Projects. The goals were:

- Describe annual and long-term changes in the arctic environment,
- Investigate extent of bottom-up and top-down control of processes in the food web, and
- Measure the land-water transfer of materials.

Progress From Previous Research: Terrestrial Studies. Our research in terrestrial ecosystems has focused on C/N/P interactions in controlling productivity and biomass accumulation of contrasting tundra types. Four tundras were studied including wet sedge tundra, moist tussock tundra, dry heath tundra, and riparian shrub tundra; each is dominated by a different plant "functional type" or growth form (e.g., rhizomatous sedges, tussock sedges, deciduous shrub, evergreen shrub). All four tundras received the same long-term manipulations including N and/or P fertilizer, greenhouse warming, reduced light (by shading), and factorial combinations of these manipulations ([Table 1](#)).

Detailed harvests have been completed for moist tussock tundra (Chapin et al. 1995, Chapin and Shaver 1996), wet sedge tundra (Shaver et al. 1998), and dry heath tundra (unpublished). All three are strongly nutrient-limited, by N and/or P, and are relatively unresponsive to warming and shading. There is a consistent but small increase in production and biomass with warming that is almost certainly due to increased nutrient availability in the soil. Eventually, shading does lead to reduced biomass but this takes more than 3-6 years. Changes in ecosystem level CO₂ fluxes (Gross Ecosystem Productivity, Ecosystem Respiration, and Net Ecosystem Productivity) are also correlated with changes in biomass (Fig. 2), with small but significant changes in CO₂ fluxes per unit N or P mass (Shaver et al. 1998). Changes in soil respiration are small relative to the changes in CO₂ fluxes with vegetation N and P mass, as are changes in the light and temperature kinetics of these CO₂ fluxes (Johnson et al. submitted).

In sum, our experimental results agree consistently with our initial conceptual model of C/N interactions (Shaver et al. 1992). Differences in species or "functional type" composition of the vegetation appear to have little qualitative effect on the overall hypothesis that C cycling in tundra can change as a result of 3 principal kinds of C/N (or C/P) interaction: (1) changes in C/N ratio within plants and/or soils, (2) changes in distribution of the total N stock between plants and soil, which differ in their characteristic C/N and C/P ratios, and (3) changes in total (actively cycled) N or P stocks (McKane et al. 1997a).

The lack of a measurable species effect on ecosystem-level response to our manipulations probably results from the fact that variation in nutrient use efficiency among species is much less than the variation in total nutrient availability to plants, both among treatments and among tundra types (Shaver and Chapin 1991, Shaver et al. 1996, Shaver and Jonasson in press). Nonetheless, there are consistent differences in plant $\delta^{15}\text{N}$, among both species and sites, indicating partitioning in N uptake (Nadelhoffer et al. 1996). Experimental addition of ¹⁵N has also shown us that species differ in depth, timing, and chemical form of N uptake (unpublished). Species composition does change, however, in our manipulations, and we have shown that the changes are related to their different morphology of growth---i.e., over several years the species differ in their potential rate of addition of new meristems (sinks), and in the shorter term in their ability to vary the amount of growth per growing meristem (Bret-Harte et al. submitted).

Synthesis and intersite comparisons have been many and varied, including long term modeling of response to climate change (McKane et al. 1997b, Rastetter et al. 1997, Williams et al. 1997), comparison of responses to warming and nutrients across the Arctic (Shaver and Chapin 1995, Molau and Shaver 1997), and writing of review articles and a book (Chapin et al. 1995, Jonasson and Shaver in press, Shaver and Jonasson in press). Recent cross site work has focused on diversity/productivity relationships, both within the arctic (Gough and Shaver submitted) and among LTER sites (Gough et al. submitted).

Progress from Prior Research: Stream Studies. The streams program has focused on long-term monitoring and whole-stream fertilization experiments in two tundra streams,

the Kuparuk River and Oksrukuyik Creek. In the past 6 years we have added two additional activities, stream surveys and intensive reach studies. The combination of process studies that accompany the stream fertilization experiments, monitoring, surveys of representative stream reaches and whole ecosystem tracer addition experiments is providing the information base for our first efforts to model the food web structure and flow of elements in arctic streams.

The Kuparuk River experiment is now in its 15th year of phosphorus fertilization ([Fig. 3](#)). The river ecosystem responds to P fertilization at the low level of only 10 μ g/l with increases in epilithic chlorophyll and primary production, increases in insect abundance in several taxa, and increases in fish production (Bowden et al. 1992, Hershey et al 1988, Deegan and Peterson 1992). One remarkable finding is that the wide variation in discharge from year to year exerts even more powerful control over insect abundance and fish growth than the nutrient enrichment (Hershey et al. 1995, Deegan and Peterson 1992). However, some taxa do better at high flow and others at low flow conditions and thus the stream community overall benefits from year to year variability in discharge. A major reorganization of the stream community only became apparent after 7 or 8 years of fertilization when a nutriophilic species of bryophyte, *Hygrohypnum* sp , began to proliferate on the river bottom ([Fig. 3](#)), Bowden et al . 1994). This moss now dominates primary production, controls insect habitat structure and hence species composition, traps tremendous quantities of fine particulates, and sloughs quantities of moss fragments and detritus during high discharge events. It may be having a negative impact on graying production but more data are needed. We have recently completed a six year fertilization study of a second stream, Oksrukuyik Creek, which exhibited several responses in parallel with the Kuparuk study (Harvey et al. in press) including increases in primary production, insect abundance and fish production ([Fig. 3](#)).

From 1991 to 1997 we performed a series of intensive one year studies of representative tundra stream reaches throughout the Kuparuk River drainage. Selected reaches included first to sixth order streams (0.2 to 30 m³/s) and a beaded stream as well as a lake outlet stream reach. In these studies our goal has been to characterize the physical and biological structure of the system, to determine the hydrological characteristics such as seepage and hyporheic exchange, and to establish nitrogen budgets and flow pathways using added stable isotopic tracers (¹⁵N-NH₄) (Hershey et al. 1993, Peterson et al. 1997). The information generated is compared to similar information from the long-term studies on the Kuparuk and Oksrukuyik Creek to judge the generality of those studies. In addition the data are employed to test and calibrate our Stable Isotope Stream Tracer Model (SISTEM) which we have developed to synthesize information on the ecosystem fluxes and budgets of nitrogen and to predict N cycling in unstudied reaches (Hall et al. in press).

During 1997 we performed more extensive one day studies of 13 spring and mountain streams that could only be reached by helicopter. In most cases we were able to sample and compare a spring stream fed by subsurface water with an adjacent stream fed by mountain surface runoff. Springs were characterized by very cold water, higher nutrient levels, higher levels of epilithic chlorophyll, by much higher levels of filamentous algae

and bryophytes, and by the presence of juvenile anadromous arctic char. Because springs flow year around, they serve as a refuge for organisms such as fishes that can not survive the freezing characteristic of other arctic streams. These surveys of contrasting stream classes are required for scaling-up our understanding of arctic streams to the watershed level.

Progress from Prior Research: Lake Studies. We have discovered that top down control is exerted at several levels in arctic lake foodwebs. In large lakes at the site, the top predator, lake trout, plays a keystone role and controls the size and density of the snail *Lymnaea* (Merrick et al. 1991) as well as the density and habitat distribution of slimy sculpin (Hanson et al. 1992, McDonald and Hershey 1992). When we tested our hypothesis about sculpin and removed all large lake trout from a lake, we were surprised to find that burbot, a minor part of the community, suddenly became very abundant. Instead of freeing the sculpin from predation, the experiment substituted another effective predator and so the sculpin became even more concentrated in rocky littoral habitat. Slimy sculpin are also effective predators and when free from predation limit their prey of chironomids to low densities in Toolik Lake (Cuker et al. 1992, Goyke and Hershey 1992). We have recently added another predator, adult grayling, to a small fishless lake and found that they eliminated the very largest zooplankton but not the intermediate sized zooplankton. However, when grayling are the sole pelagic fish in a lake these intermediate sized zooplankton are never present. Our model of grayling planktivory has resolved this paradox (see below).

We also made progress in studying bottom-up control. In a limnocorral experiment we found added nitrogen and phosphorus greatly stimulated phytoplankton growth and after a year's lag zooplankton also responded with increased densities (O'Brien et al. 1992). In a divided-lake addition of nutrients, the phytoplankton (Fig. 4) and most zooplankton species increased in abundance while *Cyclops scutifer* showed no response. Hershey (1990) found that the snail *Lymnaea* increased with added nutrients but chironomids, controlled by predaceous sculpin, did not. In the same experiment, fully half of the added phosphorus was lost to the sediments before pelagic phytoplankton could take it up (Sugai and Kipphut 1992) which illustrates how important arctic lake sediments are in sequestering nutrients, especially phosphorus (Cornwell and Kipphut 1992). This concept was further tested when we added nutrients for 5 years to a whole lake. Sediments did not remove as much of the phosphorus as predicted, leading to a rapid rate of eutrophication.

We have also continued work on the microbial diversity in arctic lakes with Rublee and Bettez (1995) and Bahr et al. (1996) reporting on the species of bacteria and protozoans.

Our bioenergetics model for lake trout (McDonald et al. 1996) will be used in conjunction with an arctic lake physical and biological model (see this proposal). Our model of the planktivorous feeding of grayling (O'Brien and Evans 1992) demonstrates that the density of grayling necessary to eliminate large bodied zooplankton from lakes is more than 10 times greater than the density needed to maintain a small-bodied zooplankton community. We also have now developed a model of the whole lake (Arctic

Lake Model or ALM) that simulates the year-long thermal pattern. ALM also simulates a year-long oxygen depletion as well as summer phytoplankton and zooplankton growth.

We have combined the bioenergetics model with the physical model to ask questions about the potential role of global change in arctic lakes (Rouse et al. 1997). Specifically a 3°C rise in July epilimnetic temperatures could cause young-of-the-year lake trout to need to consume eight times more food than is currently necessary just to maintain adequate condition (McDonald et al. 1996).

Progress From Previous Research: Land-Water Interactions. The research on land-water interactions included: (1) measuring concentrations and fluxes of carbon and nutrients in soil waters, streams, and lakes; (2) determining the impact of dissolved organic carbon (DOC) inputs from land on lake microbial metabolism; (3) estimating the rates of production of dissolved C and gases in soil waters; and (4) modeling of water flow and soil conditions using a topographically-based hydrological model.

A major advance in the last 5 years has been a better understanding of the nature of carbon cycling between ecosystems in the arctic tundra. Of particular importance in the Arctic is the pathway of dissolved carbon and trace gases (CO₂ and CH₄) which are released from the soil, move into streams and lakes, and eventually are either released to the atmosphere or enter to the ocean (Kling 1995, Kling et al. 1991). The specific processes and transformations involved during this carbon cycling have been extensively studied in lakes and streams (O'Brien et al. 1997, Hershey et al. 1997) near Toolik and have included the use of stable isotope measurements (Kling 1994). We also extended our work to a larger scale, and found that in the entire Kuparuk basin (9200 km²) the rates of loss of C from land indicate that this aquatic conduit is a major pathway for gaseous transfer from land to the atmosphere for both CO₂ and CH₄ (Kling et al. 1996, Reeburgh et al. submitted; *see later Figures*). Through a series of LTER cross-site workshops we determined that this importance of surface waters in carbon cycling at landscape-level scales is a common phenomenon throughout the world, and is not confined to arctic or wetland regions (Kling 1997, Cole et al. 1994).

The movement of DOC through lakes and streams is a dominant component of the ecosystem flux of carbon, and we showed that the DOC export from land is influenced by vegetation cover and watershed position (Kling 1995; [Fig. 5](#)). But the use of that DOC and associated DOM by organisms is controlled strongly by the material quality as well as the quantity. Our measurements indicate that the initial spring snowmelt-water leaches DOM from plants and then reaches streams by surface runoff. Soon after this time, the soils thaw and subsequent leaching results in DOM movement through soils where the DOM is metabolized by soil bacteria before reaching the streams and lakes. Experiments showed that differences in the quality of the organic carbon were related to its place of origin on the landscape and to the time of season, and this controlled the rate of conversion of organic carbon to CO₂ (Michaelson et al. submitted). We have also shown, using mesocosms (Kling 1995) and bioassays, that this DOC is accessible to lake bacteria, and that the use by bacteria depends on DOC concentration and the time of year ([Fig. 6](#)).

We have completed work on a process model that combines a soil-energy column and water balance routine with topographic statistics of the watershed (a TOPMODEL approach; see Stieglitz et al. 1997). The model predicts well the surface runoff and soil temperatures in Imnavait Creek near Toolik (see later Figures); our next step will be to incorporate DOC and gas production in the soil and export from the basin.

Finally, a recent experiment has estimated the production rate in soil waters of DOC, CO₂, and CH₄ in soil-plant microcosms using ¹⁴C (see later Figures). This information will be used in the proposed research of our LTER in formulating process-based models of the controls on production of dissolved materials in soils, which will be linked to the export of materials predicted by our hydrologic model. We will continue to assess the quality of this exported material in terms of its use by lake and stream organisms as part of our overall goal of understanding the transfers and transformations of materials in and among ecosystems across a landscape.

B. Publications from 1992 to 1998

Journal Articles

Arcscott,DB, Bowden,WB, Finlay,JC (In press) Comparison of epilithic algal and bryophyte metabolism in an arctic tundra stream, Alaska. J. N. Am. Benthol. Soc.

Arcscott,DB, Bowden,WB, Finlay,JC (Submitted) Ecophysiology of two arctic stream bryophytes. J. N. Am. Benthol. Soc.

Bahr,M, Hobbie,JE, Sogin,ML (1996) Bacterial diversity in an arctic lake: a freshwater SAR11 cluster. Aquat. Microb. Ecol. 11:271-277.

Berendonk,T, O'Brien,WJ (1996) Movement response of *Chaoborus* to chemicals from a predator and prey. Limnol. Oceanogr. 41:1829-1832.

Bettez,ND, Rublee,P, O'Brien,WJ, Miller,MC. (Submitted) Changes in abundance, composition and controls within the microbial loop of a fertilized arctic lake. Limnol. Oceanogr.

Bowden,WB, Finlay,JC, Maloney,PE (1994) Long-term effects of PO₄ fertilization on the distribution of bryophytes in an arctic river. Freshwater Biol. 32:445-454.

Bowden,WB, Peterson,BJ, Finlay,JC, Tucker,J (1992) Epilithic chlorophyll a, photosynthesis and respiration in a tundra stream. Hydrobiologia 240: 121-132.

Bret-Harte,MS, Shaver,GR, Zoerner,JP, Johnstone,JF, Wagner,JL, Chavez,AS, Gunkelman, RF, Lippert,SC, Laundre,JA (Submitted) Individual growth and species performance of three arctic shrubs exposed to long-term warming and fertilization in Alaskan tussock tundra. Ecology.

- Chapin,FS,III, Shaver,GR (1996) Physiological and growth responses of arctic plants to a field experiment simulating climatic change. *Ecology* 77: 822-840.
- Chapin,FS,III, Shaver,GR, Giblin,AE, Nadelhoffer,KJ, Laundre,JA (1995) Responses of arctic tundra to experimental and observed changes in climate. *Ecology* 76:694-711.
- Chapin,FS,III, Zimov,SA, Shaver,GR, Hobbie,SE (1996) CO₂ fluctuation at high latitudes. *Nature* 383:585-586.
- Cole,JJ, Caraco,N, Kling,GW, Kratz,T (1994) Carbon dioxide supersaturation in the surface waters of lakes. *Science* 265:1568-1570.
- Cornwell,JC (1992) Cation export from Alaskan arctic watershed. *Hydrobiologia* 240: 15-22.
- Cornwell,JC, Banahan,S (1992) A silicon budget for an Alaskan arctic lake. *Hydrobiologia* 240:37-44.
- Cornwell,JC, Kipphut,GW (1992) Biogeochemistry of manganese- and iron-rich sediments in Toolik Lake, Alaska. *Hydrobiologia* 240:45-59.
- Cuker,BE, McDonald,ME, Mozley,SC (1992) Influences of slimy sculpin (*Cottus cognatus*) predation on the rocky littoral invertebrate community of an arctic lake. *Hydrobiologia* 240:83-90.
- Deegan,LA, Golden,HE, Harvey,CJ, Peterson,BJ (Submitted) The influence of environmental variability on the growth of young-of-the-year and adult grayling (*Thymallus arcticus*, *Pallus*) in two arctic tundra streams. *Trans. Amer. Fish. Soc.*
- Deegan,LA, Peterson,BJ (1992) Whole river fertilization stimulates fish production in an arctic tundra river. *Can. J. Fish. Aquat. Sci.* 49:1890-1901.
- Deegan,LA, Peterson,BJ, Golden,H, MacIvor,C, Miller,M (1997) The effects of fish density and river fertilization on algal standing stock, invertebrate communities and fish production in an Arctic river. *Can. J. Fish. Aquat. Sci.* 54:269-283.
- Deegan,LA, Peterson,BJ, Harvey,CJ (Submitted) Population size, growth and overwintering of Arctic grayling in the headwater lakes of the Kuparuk River. *Can. J. Fish. Aquat. Sci.*
- Douglas,M, Hecky,RE, Hershey,A, Kling,GW, Lesack,L, Marsh,P, McDonald,M, Nicholson,B, Roulet,N, Smol,J (1997) Effects of climate change on fresh waters of region 2: arctic and subarctic North America. *Hydrol. Proc.* 11:873-902.

Edwardson,KJ, Bowden,WB (Submitted) Hyporheic nutrient processing in arctic tundra streams. *J. N. Am. Benthol. Soc.*

Edwardson,KJ, Bowden,WB, Dahm C, Morrice J (Submitted) Transient storage and hyporheic transport in arctic tundra streams. *J. N. Am. Benthol. Soc.*

Finlay,JC, Bowden,WB (1994) Controls on production of bryophytes in arctic tundra stream. *Freshwater Biol.* 32, 455-466.

Fraser,NC, Power,G (1989) Influences of lake trout on lake-resident Arctic char in northern Quebec, Canada. *Trans. Am. Fish. Soc.* 118:36-45.

Gettel,GM, Deegan,LA, Harvey,CJ (1997) A comparison of whole and thin-sectioned otolith aging methods for arctic grayling and validation of annuli. *Northwest Sci.* 71:224-232.

Giblin,AE, Laundre,J, Nadelhoffer,K, Shaver,G (1994) Measuring nutrient availability in arctic soils using ion-exchange resins: a field test. *Soil Sci. Soc. Am. J* 58:1154-1162.

Golden,H, Deegan,LA (In press) Top-down control by young-of-the-year grayling in a tundra stream. *Freshwater Biol.*

Golden,H, Deegan,LA, Peterson,BJ, Harvey,C (In press) Influence of summer stream flow and temperature on the growth of adult and young-of-the-year Arctic grayling. *Trans. Amer. Fish. Soc.*

Gough, L, Gross,KL, Collins, SL, Osenberg,CW (Submitted) Fertilization effects on plant species diversity in herbaceous plant communities. *Ecology*, Special feature section on diversity/productivity relationships.

Gough, L, Shaver,GR (Submitted) Diversity/productivity relationships in arctic vegetation. *Ecology*, Special feature section on diversity/productivity relationships.

Goyke,AP, Hershey,AE (1992) Effects of fish predation on larval chironomid (Diptera:Chironomidae) communities in an arctic ecosystem. *Hydrobiologia* 240: 203-212.

Gu,B, Schell,DM, Alexander,V (1994) Stable carbon and nitrogen isotope analysis of a plankton food web in a subarctic lake. *Can. J. Fish. Aquat. Sci.* 51:1338-1344.

Hagan,RH, O'Brien,WB, Slaymaker,AK (Submitted) Diversity and distribution on *Daphnia* clones on the Alaska North Slope (Toolik Lake area). *Mol. Ecol.*

Hall,RO Jr, Peterson, BJ, Meyer,JL (Submitted) Testing a nitrogen cycling model of a forest stream using a ¹⁵N tracer addition. Ecosystems.

Hanson,KL, Hershey,AE, McDonald,ME (1992) A comparison of slimy sculpin (*Cottus cognatus*) populations in arctic lakes with and without piscivorous predators. Hydrobiologia 240:189-202.

Hansson,S, Hobbie,JE, Elmgren,R, Larsson,U, Fry,B, Johansson,S (In press) The stable nitrogen isotope ratio as a marker for food web interactions and fish migration - a comparison of three coastal Baltic Sea stations. Ecology.

Harvey,CJ, Peterson,BJ, Bowden,WB, Deegan,LA, Finlay,JC, Hershey,AE, Miller,MC (1997) Organic matter dynamics in the Kuparuk River, a tundra river in Alaska, USA. J. N. Am. Benthol. Soc.16:18-22.

Harvey,CJ, Peterson,BJ, Bowden,WB, Hershey,AE, Miller,MC, Deegan,LA, Finlay,JC (In press) Biological responses of Oksrukuyik Creek, a tundra stream, to fertilization. J. N. Am. Benthol. Soc.

Hershey,AE (1992) Effects of experimental fertilization on the benthic macroinvertebrate community of an arctic lake. J. N. Am. Benthol. Soc. 11:204-217.

Hershey,AE, Gettel,G, McDonald,ME, Miller,MC, Mooers,H, O'Brien,WJ, Pastor,J, Richards,C, Schuldt,JA (Submitted) A geomorphic-trophic model for landscape control of trophic structure in arctic lakes. Bioscience.

Hershey,AE, Pastor,J, Peterson,BJ, Kling,GW (1993) Stable isotopes resolve the drift paradox for *Baetis* mayflies in an arctic river. Ecology 74:2315-2325.

Hiltner,AL, Hershey,AE (1992) Blackfly (Diptera:Simuliidae) responses to phosphorus enrichment of an arctic tundra stream. Hydrobiologia 240:259-266.

Hinterleitner-Anderson,D, Hershey,AE, and J.A. Schuldt (1992) The effects of river fertilization of Mayfly (*Baetis* sp.) drift patterns and population density in an arctic river. Hydrobiologia 240:247-258.

Hobbie,JE, Bahr,M, Rublee,P (In press) Controls on microbial food webs in oligotrophic arctic lakes. Arch. Hydrobiol. Beih.

Hobbie,JE, Kwiatkowski,BL, Rastetter,EB, Walker,DA, McKane,RB (Submitted) Carbon cycling in the Kuparuk basin: plant production, carbon storage, and sensitivity to future changes. J. Geophys. Res.

Hobson,K, Schell,DM, Renouf,D, Noseworthy,E (1996) Stable carbon and nitrogen isotopic fractionation between diet and tissues of captive seals:

implications for dietary reconstructions involving marine mammals. *Can. J. Fish. Aquat. Sci.* 53:528-533.

Holmes, RM, McClelland, JW, Sigman, DM, Fry, B, Peterson, BJ (1997) Measuring $^{15}\text{N-NH}_4^+$ in marine, estuarine and fresh waters: an adaptation of the ammonia diffusion method for samples with low ammonium concentrations. *Mar. Chem.*

Jeffries, RL, Klein, DR, Shaver, GR (1994) Herbivores and northern plant communities: reciprocal influences and responses. *Oikos* 71:193-206.

Johnson, Loretta, G.R. Shaver, D. Cades, E. Rastetter, K.J. Nadelhoffer, A. Giblin, J. Laundre, and A. Stanley (Submitted) Carbon-nutrient interactions control CO_2 exchange in Alaskan wet sedge ecosystems. *Ecology*.

Johnson, LC, Shaver, GS, Giblin, AE, Nadelhoffer, KJ, Rastetter, EB, Laundre, JA, Murray, GL (1996) Effects of drainage and temperature on carbon balance of tussock tundra microcosms. *Oecologia* 108:737-748.

Jonasson, S, Shaver, GR (Submitted) Within-stand nutrient cycling in arctic and boreal herbaceous and forested wetlands. *In* D. Whigham and I. Feller (eds.) Special Features section on Wetland Ecosystems. *Ecology*.

Kipphut, GW, Whalen, SC (1992) Access pipes for sampling through thick ice. *Hydrobiologia* 240: 267-269.

Kling, GW (1997) Patterns and causes of CO_2 saturation in surface waters at landscape and continental scales: results of a multi-investigator workshop. American Society of Limnology and Oceanography, National Meeting, 10-14 February 1997, Santa Fe, NM p210.

Kling, GW, Kipphut, GW, Bowden, WB, Edwardson, K (1996) Carbon balance in arctic regions: the role of lakes and streams. American Geophysical Union, National Meeting, 15-19 December, San Francisco. P.F257.

Kling, GW, Fry, B, O'Brien, WJ (1992) Stable isotopes and planktonic trophic structure in arctic lakes. *Ecology* 73: 561-566.

Kling, GW, Kipphut, GW, Miller, MC (1992) The flux of CO_2 and CH_4 from lakes and rivers in arctic Alaska. *Hydrobiologia* 240: 23-36.

Kling, GW, O'Brien, WJ, Miller, MC, Hershey, AE (1992) The biogeochemistry and zoogeography of lakes and rivers in arctic Alaska. *Hydrobiologia* 240: 1-14.

Kriet, K, Peterson, BJ, Corliss, TL (1992) Water and sediment export of the Upper Kuparuk River drainage of the North Slope of Alaska. *Hydrobiologia* 240:71-81.

- McDonald,ME, Hershey,AE (1992) Shifts in abundance and growth of slimy sculpin in response to changes in the predator population in an arctic Alaskan lake. *Hydrobiologia* 240:219-224.
- McDonald,ME, Hershey,AE, Miller,MC (1996) Global warming impacts on lake trout in arctic lakes. *Limnol. Oceanogr.* 41:1102-1108.
- McDonald,ME, Hershey,AE, O'Brien,WJ (1992) Cost of predation avoidance in young-of-year lake trout (*Salvelinus namaycush*) growth differential in sub-optimal habitats. *Hydrobiologia* 240:213-218.
- McDonald,ME, Tikkanen,CA, Axler,RP, Larsen,CP, Host,G (1995) Fish simulation model (FIS-C) A bioenergetics based model for aquacultural wasteload applications. *Aquacult. Engineer.* 14.
- McKane,RB, Rastetter,EB, Shaver,GR, Nadelhoffer,KJ, Giblin,AE, Laundre,JA, Chapin,FSIII (1997) Reconstruction and analysis of historical changes in carbon storage in arctic tundra. *Ecology* 78:1188-1198.
- McKane,RB, Rastetter,EB, Shaver,GR, Nadelhoffer,KJ, Giblin,AE, Laundre,JA (1997) Climatic effects on tundra carbon storage inferred from experimental data and a model. *Ecology* 78:1170-1187.
- Meile,M, Fry,B, Kling,GW (1993) Fractionation of stable isotopes (^{13}C , ^{15}N) in the food web of a humic lake. *Verein. Internat. Limnol.* 25:501-505.
- Meili,M, Kling,GW, Fry,B, Bell,RT, Ahlgren,I (1996) Sources and partitioning of organic matter in a pelagic microbial food web inferred from the isotopic composition ($\delta^{13}\text{C}$ and $\delta^{15}\text{N}$) of zooplankton species. *Arch. Hydrobiol. Beih.* 48:53-61.
- Merrick,GW, Hershey,AE, McDonald,ME (1992) Salmonid diet and the size, distribution, and density of benthic invertebrates in an arctic lake. *Hydrobiologia* 240:225-234.
- Michaelson,GJ, Ping,CL, Kling,GW, Hobbie,JE (Submitted) The character and bioactivity of dissolved organic matter at thaw and in the spring runoff waters of the Arctic Tundra North Slope, Alaska. *J. Geophys. Res.*
- Miller,MC, DeOliveira,P, Gibeau,GG (1992) Epilithic diatom community response to years of PO_4 fertilization: Kuparuk River, Alaska (68°N Lat.). *Hydrobiologia* 240:103-120.
- Molau,J, Shaver,GR (1997) Controls on seed production and seed germinability in *Eriophorum vaginatum*. *Global Change Biology*, Special issue on ITEX research. 3 suppl.1.

- Moosavi,SC, Crill,PM (In press) CH₄ oxidation by tundra wetlands as measured by a selective inhibitor technique. J. Geophys. Res.
- Nadelhoffer,KJ, Shaver,GR, Giblin,AE, Johnson,L, McKane,R (1996) ¹⁵N natural abundances and N use by tundra plants. Oecologia 107:386-394.
- O'Brien,WJ (In press) Benthic animal distributions among Alaskan north slope lakes. Hydrobiologia.
- O'Brien,WJ (Submitted) Impact of an invertebrate predator *Heterocope* on the zooplankton communities in arctic ponds. Ecology.
- O'Brien,WJ, Evans,BI (1992) Simulation model of the planktivorous feeding of arctic grayling: laboratory and field verification. Hydrobiologia 240:235-246.
- O'Brien,WJ, Hershey,A, Hobbie,J, Hullar,MA, Kipphut,GW, Miller,MC, Moller,B, Vestal,JR (1992) Control Mechanisms of arctic lake ecosystems: a limnocorral experiment. Hydrobiologia 240:143-188.
- O'Brien,WJ, Hershey,A, Hobbie,JE, Kipphut,G, Kling,G, McDonald,ME, Miller, MC, Moller,B (Submitted) Responses of a partitioned arctic lake to nutrient addition. Hydrobiologia.
- O'Brien,WJ, Maurer,EF, Ayurista,P (Submitted) The demographic costs of vertical migration by cladoceran zooplankton in arctic lakes. Limnol. Oceanogr.
- Peterson,BJ, Bahr,M, Kling,GW (1997) A tracer investigation of nitrogen cycling in a pristine tundra river. Can. J. Fish. Aquat. Sci. 54.
- Peterson,BJ, Corliss,TL, Kriet,K, Hobbie,JE (1992) Nitrogen and phosphorus concentration and export for the Upper Kuparuk River on the North Slope of Alaska in 1980. Hydrobiologia 240:61-69.
- Peterson,BJ, Deegan,L, Helfrich,J, Hobbie,JE, Hullar,M, Moller,B, Ford,TE, Hershey,A, Hiltner,A, Kipphut,G, Lock,MA, Feibig,DM, McKinley,V, Miller,MC, Vestal,JR, Venutllo,R, Volk,G (1993) Biological response of a tundra river to fertilization. Ecology 74:653-672.
- Peterson,BJ, Fry,B, Deegan,L, Hershey,AE, Schell,D (1992) The trophic significance of epilithic algal production in a fertilized tundra river ecosystem. Limnol. Oceanogr. 38:872-878.
- Peterson,BJ, Wollheim,WJ, Deegan,LA, Bahr,M, Jones,D, Bowden,WB, Hershey,AE, Kling,GW, Miller,MC (Submitted) A coupled field and modeling approach for the study of nitrogen cycling in streams: the Kuparuk River case study. J. N. Am. Benthol. Soc.

Rastetter,EB (1996) Validating models of ecosystem response to global change. *Bioscience* 46(3)190-198.

Rastetter,EB, Agren,GI, Shaver,GR (1997) Responses to increased CO₂ concentration in N-limited ecosystems: application of a balanced-nutrition, coupled-element-cycles model. *Ecol. Appl.* 7:444-460.

Rastetter,EB, King,AW, Cosby,BJ, Hornberger,GM, O'Neill,RV, Hobbie,JE (1992) Aggregating fine-scale ecological knowledge to model coarser-scale attributes of ecosystems. *Ecol. Appl.* 2:55-70.

Rastetter,EB, McKane,RB, Shaver,GR, Melillo,JM (1992) Changes in C storage by terrestrial ecosystems: how C-N interactions restrict responses to CO₂ and temperature. *Water Air Soil Poll.* 64:327-344.

Rastetter,EB, Shaver,GR (1992) A model of multiple element limitation for acclimating vegetation. *Ecology* 73:1157-1174.

Reeburgh,WS, King,JY, Regli,SK, Kling,GW, Auerbach,NA, Walker,DA (Submitted) A CH₄ emission estimate for the Kuparuk River Basin, Alaska. *J. Geophys. Res.*

Rouse,WR, Douglas,MS, Hecky,RE, Hershey,GW, Lesack,L, Marsh,P, McDonald,M, Nicholson,BJ, Roulet,NT, Smol,JP (1997) Effects of climate change on fresh waters of region 2: arctic and subarctic North America. *Hydrolog. Proc.* 11:873-902.

Rublee,PA (1992) Community structure and bottom-up regulation of heterotrophic microplankton in arctic LTER lakes. *Hydrobiologia* 240:133-142.

Rublee, PA, Bettez, N (1995) Change of microplankton community structure in response to fertilization of an arctic lake. *Hydrobiologia* 312:183-190.

Shaver,GR, Billings,WD, Chapin,FS, Giblin,AE, Nadlehoffer,KJ, Oechel,WC, Rastetter,EB (1992) Global change and the carbon balance of arctic ecosystems. *Bioscience* 42:433-441.

Shaver,GR, Chapin,FS,III (1995) Long-term responses to factorial NPK fertilizer treatment by Alaskan wet and moist tundra sedge species. *Ecography* 18:259-275.

Shaver,GR, Johnson,LC, Cades,DH, Murray,G, Laundre,JA, Rastetter,EB, Nadelhoffer,KJ, Giblin,AE (1998) Biomass accumulation and CO₂ flux in three Alaskan wet sedge tundras: Responses to nutrients, temperature, and light. *Ecol. Monographs* 68:75-98.

Shaver,GR, Laundre,JA (1997) Leaf exsertion, leaf elongation, and leaf senescence in *Eriophorum vaginatum* and *Carex bigelowii* in northern Alaska. Global Change Biology, Special Issue on ITEX Research 3 suppl.1..

Shaver,GR, Laundre,JA, Giblin,AE, Nadelhoffer,KJ (1996) Changes in vegetation biomass, primary production, and species composition along a riverside toposequence in arctic Alaska. Arct. Alp. Res. 28:363-379.

Sugai,SF, Kipphut,GW (1992) The influence of light and nutrient addition upon the sediment chemistry of iron in an arctic lake. Hydrobiologia 240:91-101.

Vallino,JJ, Hopkinson,CS, Hobbie,JE (1997) Modeling bacterial utilization of dissolved organic matter: Optimization replaces monod growth kinetics. Limnol. Oceanogr. 41:1591-1609.

Weller,G, Chapin,FS, Everett,KR, Hobbie,JE, Kane,D, Oechel,WC, Ping,CL, Reeburgh,WS, Walker,D, Walsh,J (1995) The arctic flux study: a regional view of trace gas release. J. Biogeogr. 22:365-374.

Williams,M, Rastetter,EB, Fernandes,DN, Goulden,ML, Shaver,GR (1997) Predicting gross primary productivity in terrestrial ecosystems. Ecol. Appl. 7:882-894.

Williams,M, Rastetter,EB, Fernandes,DW, Goulden,ML, Wofsy,SC, Shaver,GR, Melillo,JM, Munger,JW, Fan,S-M, Nadelhoffer,KJ (1996) Modeling the soil-plant-atmosphere continuum in a *Quercus-Acer* stand at Harvard Forest: The regulation of stomatal conductance by light, nitrogen, and soil/plant hydraulic properties. Plant Cell Environ. 19:911-927.

Books and Book Chapters:

Agren,G, Shaver,GR, Rastetter,EB (In press) Nutrients: dynamics and limitations. In Luo,Y, Mooney,HA (eds.) Carbon Dioxide and Environmental Stress. Academic Press, NY.

Chapin,FS,III, Hobbie,SE, Shaver,GR (1997) Impacts of global change on composition of arctic communities: implications for ecosystem functioning. In Oechel,WC, Holten,J (eds.) Global Change and Arctic Terrestrial Ecosystems. Springer-Verlag, NY.

Chapin,FS,III, Jefferies,R, Reynolds,R, Shaver,GR, Svoboda,J (1992) Arctic plant physiological ecology: a challenge for the future. In Chapin,FS,III, Jefferies,R, Reynolds,R, Shaver,GR, Svoboda,J (eds.) Arctic Ecosystems in a Changing Climate: An Ecophysiological Perspective. Academic Press, NY. p. 441-452.

Chapin,FS,III, Jefferies,R, Reynolds,R, Shaver,GR, Svoboda,J (1992) Arctic physiological ecology in an ecosystems context. *In* Chapin,FS,III, Jeffries,R, Reynolds,R, Shaver,GR, Svoboda,J (eds.) Arctic Ecosystems in a Changing Climate: An Ecophysiological Perspective. Academic Press, NY. p. 3-10.

Chapin,FS,III, Jefferies,R, Reynolds,R, Shaver,GR, Svoboda,J (eds.) (1992) Arctic Ecosystems in a Changing Climate: An Ecophysiological Perspective. Academic Press, NY. 469 pages.

Fry,B, Jones,DE, Kling,GW, McKane,RB, Nadelhoffer,KJ, Peterson,BJ (1995) Adding ¹⁵N tracers to ecosystem experiments. *In* Wada,E, Yoneyama,T, Minegawa,M, Ando,T, Fry,B (eds.) Stable Isotopes in the Biosphere. Kyoto University Press, Kyoto, Japan. p. 171-192.

Hershey,AE, Bowden,WB, Deegan,LA, Hobbie,JE, Peterson,BJ, Kipphut,GW, Kling,GW, Lock,MA, Merritt,RW, Miller,MC, Vestal,JR, Schuldt,JA (1997) The Kuparuk River: A long-term study of biological and chemical processes in an arctic river. *In* Milner,A, Oswood,MW (eds.) Freshwaters of Alaska. Springer-Verlag, NY. p. 107-130.

Hershey,AE, Lamberti,GA (In press) Stream macroinvertebrate communities. *In* Bilby,RE, Naiman,RJ (eds.) Ecology and Management of Streams and Rivers in the Pacific Northwest Coastal Regions. Springer-Verlag, NY.

Hershey,AE, Merritt,RW, Miller,MC (1995) Insect diversity, life history, and trophic dynamics in arctic streams, with particular emphasis on blackflies (Diptera: Simuliidae). *In* Chapin,FS,III, Koerner,K (eds.) Arctic and Alpine Biodiversity. Ecological Studies Vol. 113. Springer-Verlag, Berlin. p. 283-295.

Hershey,AE, Peterson,BJ (1996) Stream food webs. *In* Lamberti,GA, Hauer,FR (eds.) Methods in stream ecology. Academic Press, San Diego, CA. p. 511-530.

Hobbie,JE (1993) Arctic Ecosystem Response to Change. *In* Arctic Research of the United States, vol. 7. p.2-9.

Hobbie,JE (1993) Introduction. *In* Kemp,PF, Sherr,BF, Sherr,EB, Cole,JJ (eds.) Handbook of Methods in Aquatic Microbial Ecology. Lewis Publishers, Boca Raton, FL. p. 1-5.

Hobbie,JE (1996) History of limnology in Alaska. *In* Milner,A, Oswood,MW (eds.) Freshwaters of Alaska. Springer-Verlag, NY. p. 45-60.

Hobbie,JE, Deegan,LA, Peterson,BJ, Rastetter,EB, Shaver,GR, Kling,GW, O'Brien,WJ, Chapin,FST, Miller,MC, Kipphut,GW, Bowden,WB, Hershey,AE, McDonald,ME (1995) Long-term measurements at the Arctic LTER site. *In*

Powell,TM, Steele,JH (eds.) Ecological Time Series. Chapman and Hall, NY. p. 391-409.

Hobbie,JE, Ford,TE (1993) A perspective on the ecology of aquatic microbes. *In* Ford,TE (ed.) Aquatic Microbiology: An Ecological Approach. Blackwell Scientific Publications, Boston, MA. p. 1-14.

Kling,GW (1994) Ecosystem-scale experiments in freshwaters: the use of stable isotopes. *In* Baker,LA (ed.) Environmental Chemistry of Lakes and Reservoirs, Advances in Chemistry Series. American Chemical Society, Washington, DC. p. 91-120.

Kling,GW (1995) Land-water linkages: the influence of terrestrial diversity on aquatic systems. *In* Chapin,FS, Korner,C (eds.) The role of biodiversity in arctic and alpine tundra ecosystems. Springer-Verlag, Berlin. p. 297-310.

Michener,RH, Schell,DM (1994) The use of stable isotopes in tracing marine aquatic food webs. *In* Ljatha,K, Michener,R (eds.) Stable Isotopes in Ecology and Environmental Science. Blackwell Scientific Publications, London. p. 138-157.

Nadelhoffer,KJ, Linkins,AE, Giblin,AE, Shaver,GR (1992) Microbial processes and plant nutrient availability in arctic soils. *In* Chapin,FS,III, Jeffries,R, Reynolds,R, Shaver,GR, Svoboda,J (eds.) Arctic Ecosystems in a Changing Climate: An Ecophysiological Perspective. Academic Press, NY. p. 281-300.

Nadelhoffer,KJ, Shaver,GR, Giblin,AE, Rastetter,EB (In press) Potential impacts of climate change on nutrient cycling, decomposition and productivity in arctic ecosystems. *In* Oechel,WC, Holten,J (eds.) Global Change and Arctic Terrestrial Ecosystems. Springer-Verlag, NY.

O'Brien,WJ, Bahr,M, Hershey,AE, Hobbie,JE, Kipphut,GW, Kling,GW, Kling,H, McDonald,M, Miller,MC, Rublee,P, Vestal,JR (1997) The limnology of Toolik Lake. *In* Milner,A, Oswood,MW (eds.) Freshwaters of Alaska. Springer-Verlag, NY. p. 61-106.

Rastetter,EB, McKane,RB, Shaver,GR, Nadelhoffer,KJ, Giblin,AE (1997) Analysis of CO₂, temperature, and moisture effects on carbon storage in Alaskan arctic tundra using a general ecosystem model. *In* Oechel,WC, Holten,J (eds.) Global Change and Arctic Terrestrial Ecosystems. Springer-Verlag, NY.

Rastetter,EB, Shaver,GR (1995) Functional redundancy and process aggregation: Linking ecosystems to species. *In* Jones,CG, Lawton,JH (eds.) Linking Species and Ecosystems. Chapman and Hall, NY. p. 215-223.

Rouse,WR, Douglas,MS, Hecky,RE, Hershey,GW, Lesack,L, Marsh,P, McDonald,M, Nicholson,BJ, Roulet,NT, Smol,JP (1995) Region 2 - Arctic and

sub-Arctic, North America. *In* McNight,DM, Weiler,CS (eds.) Symposium Report on Regional Assessment of Freshwater Ecosystems and Climate Change in North America. USGS-WRD, Boulder,CO. p 4-5.

Shaver,GR (1996) Integrated ecosystem research in northern Alaska, 1947-1994. *In* Reynolds,J, Tenhunen,J (eds.) Landscape Function and Disturbance in Arctic Tundra. Springer-Verlag Ecological Studies Series Vol. 120. Springer-Verlag, Heidelberg, Germany.

Shaver,GR (1995) Plant functional diversity and resource control of primary production in Alaskan arctic tundras. *In* Korner,C, Chapin,FS III (eds.) Arctic and Alpine Biodiversity: Patterns, Causes, and Ecosystem Consequences. Springer-Verlag Ecological Studies Series Vol. 113. Springer-Verlag, NY. p. 199-212.

Shaver,GR (1998) A history of research. *In* Walker, DW (ed.) A Geobotanical Atlas of the Toolik Lake and Kuparuk River Region, Alaska. This atlas is online at <http://www.Colorado.Edu/INSTAAR/TEAML/atlas/chapters/regdesc/history.html>

Shaver,GR, Aber,JD (1996) Carbon and nutrient allocation in terrestrial ecosystems. *In* Melillo,J, Breymeyer,A (eds.) Global Change: Effects on Coniferous forests and Grasslands. SCOPE Synthesis Series. John Wiley, NY. p. 183-198.

Shaver,GR, Giblin,AE, Nadelhoffer,KJ, Rastetter,EB (1996) Plant functional types and ecosystem change in arctic. *In* Smith,T, Shugart,H, Woodward (eds.) Plant Functional Types. Cambridge University Press, Cambridge, UK.

Shaver,GR, Jonasson,S (Submitted) Productivity of Arctic Ecosystems. *In* Mooney,H, Roy,J, Saugier,B (eds.) Terrestrial Global Productivity. Academic Press, NY.

Shaver,G, Kummerow,J (1992) Phenology, resource allocation, and growth of arctic vascular plants. *In* Chapin,FS, Jeffries,R, Reynolds,R, Shaver,G, Svoboda,J (eds.) Arctic Ecosystems in a Changing Climate: An Ecophysiological Perspective. Academic Press, NY. p. 193-212.

Shaver,GR, Rastetter,EB, Giblin,AE, Nadelhoffer,KJ (1997) Carbon-nutrient interactions as constraints on recovery of arctic ecosystems from disturbance. *In* Crawford,RMM (ed.) Disturbance and Recovery in Arctic Lands: An Ecological Perspective. Special issue on ITEX research. Kluwer Academic Publishers, Dordrecht, The Netherlands. p. 553-562.

Dissertations and Theses:

Arscott,D (1997) Comparison of epilithic algal and bryophyte metabolism in an arctic tundra stream, Alaska. MS Thesis. University of New Hampshire, Durham, NH.

Bettez,ND (1996) Changes in abundance, species composition and controls within the microbial loop of a fertilized arctic lake. MS Thesis, University of North Carolina, Greensboro, NC.

Edwardson, KJ (1997) Characterization of hyporheic influences on the hydrology and geochemistry in contrasting arctic streams. MS Thesis, University of New Hampshire, Durham, NH.

Galarowicz,TL (1994) Effects of slimy sculpin (*Cottus cognatus*) removal on sculpin and chironomid (Diptera: Chironomidae) populations in an arctic lake. MS Thesis, University of Minnesota, Duluth, MN.

Golden,H. (1997) Ecology of young-of-the-year arctic grayling. MS Thesis. University of Massachusetts, Amherst, MA.

Hanson,KL (1993) A comparison of slimy sculpin (*Cottus cognatus*) populations in arctic lakes with implications for the role of piscivorous predators. MS Thesis, University of Minnesota, Duluth, MN.

Harrison,J (1995) Young-of-the-year arctic grayling (*Thymallus arcticus*) metabolism: Scaling with size, temperature and flow. Senior Honor Thesis, Brown University, Providence, RI.

Naber,AC (1996) The effects of simulated herbivory on arctic woody shrubs: a test of a resource allocation hypothesis in response to herbivory. MS Thesis, University of Toronto, Canada.

Partusch-Talley,A (1994) Microfaunal response to fertilization of an arctic tundra river. MS Thesis, University of North Carolina, Greensboro, NC.

Wheeler,JR (1994) Factors affecting black fly abundance and distribution in an arctic stream. MS Thesis, University of Minnesota, Duluth, MN.

Wright, A (1996) The effect of whole-river fertilization on production of young-of-the-year arctic grayling in two arctic tundra streams. Senior Thesis. Hampshire College, Amherst, MA.

Yurista,PM (1997) Physiology and energy budgets of two cladocerans, *Bythotrephas* and *Daphnia*. Ph.D. Dissertation, University of Michigan, Ann Arbor, MI.

Other Publications:

Edwardson, K 1994. Instream storage and transport characteristics of the 1994 new reach study (Blueberry Creek). REU Project.

McGuire, AD, Hobbie, JE (1997) Global climate change and the equilibrium responses of carbon storage in arctic and subarctic regions. *In* Modeling the Arctic System: A Workshop Report on the State of Modeling in the Arctic System Science Program. The Arctic Research Consortium of the United States. Fairbanks, AK. p. 53-54.

Schell, DM (1993) Bomb radiocarbon in arctic Alaskan aquatic and terrestrial biota. *In* Adushkin, V, Krasilov, G (eds.) Radioactivity and Environmental Security in the Oceans: New Research and Policy Priorities in the Arctic and North Atlantic. Woods Hole Oceanographic Institution, Woods Hole, MA. p. 135-144.

C. Data Sets on the Arctic LTER Database

The Arctic LTER data base is available on the Arctic LTER's World Wide Web Site at www.mbl.edu/html/ECOSYSTEMS/lterhtml/arc.html. The data base also can be accessed directly at www.mbl.edu/html/ECOSYSTEMS/lterhtml/dabase1.html. All data sets are linked to the LTER network's All-Site LTER Data Catalog at www.vcrlter.virginia.edu/nis/toclist.html#LTER data catalog, and can be searched by keyword both within the Arctic LTER and across all LTER sites.

The Arctic LTER data base includes well over 1000 individual data sets, most of them annual updates of data collected yearly and stored in the same format (many are available in a choice of formats, e.g., ASCII files or EXCEL workbooks). These data sets are arranged hierarchically into 6 major categories including (1) Lakes, (2) Rivers and Streams, (3) Terrestrial, (4) Land/Water Interface, (5) Weather, and (6) GIS/Maps. The general contents of each of these major categories of data are described below.

The Arctic LTER project does not track the number of "hits" to its data base, or the location or identity of those who use it. However, we do know that the data base has been used in intersite activities of the LTER network and other networks. The most extensive use has been by the LTER Working Group on Biodiversity and Productivity, which compared our data with those from several other sites in a meta-analysis of species richness/productivity relationships, leading to two recently-submitted manuscripts (Gough et al. submitted, Gough and Shaver submitted). Our data on leaf growth were used at a workshop of the International Tundra Experiment (ITEX), in a comparison of response to temperature manipulation at several arctic and alpine sites (M. Walker et al. in preparation). We also have contributed data to the LIDET multisite decomposition experiment.

ARC LTER Data Sets. Over 1,000 data sets are currently available electronically through our web site (www.mbl.edu/html/ECOSYSTEMS/lterhtml/dabase1.html). Many of these files are yearly collections. Therefore the following list is organized by general topic.

Lakes Data

Chlorophyll and Primary Productivity. Lakes sampled every 7-10 days: Toolik lake (1975-88, 91-97); Lake N1 (89-97); Lake N2 reference and Treatment (85-97). Lakes sampled 2-4 times each summer: Lake E1 (91-97); I series (91-97); I6 (92-97); I8 (92-97); NE 12 (91-97); NE-9b (93-97); S6 (91-97); S7 (91, 96, 97); S1 (92, 95-97); S2 (92, 95-97); S11 (92-97). Surveys: Fog (92,96); coastal plain (94-97); N3,4,5 (92); I series lakes (97); Geomorphic trophic hypothesis (96, 97); Paleo (97); west lakes (97); NE14 (97), S3,4 (92).

Nutrients. Lakes sampled every 7-10 days: Toolik lake (1990-97); Lake N1 (89-97); Lake N2 reference and Treatment (85-97); Limno Bay (83-86, 89-90). Lakes sampled 2-4 times each summer: Lake E1 (90-97); I series (91-97); I6 (90-97); I8 (90-97); NE 12 (90-97); NE-9b (92-97); S6 (90-97); S7 (90, 91, 96, 97); S1 (92, 95-97); S2 (95-97); S11 (92-97). Surveys Fog 90, 92,96); coastal plain (95-97); N3,4,5 (92); NE lakes (92); I series lakes (97); Geomorphic trophic hypothesis 96, 97); Paleo (97); west lakes (97); NE14 (97), S3,4 (92).

Physical and Chemistry. Depth profiles of temperature, pH, alkalinity, dissolved oxygen, light penetration and conductivity: Lakes sampled every 7-10 days: Toolik lake (1975-80, 83 97); Lake N1 (89-97); Lake N2 reference and Treatment (85-97); Limno Bay (89). Lakes sampled 2-4 times each summer: Lake E1 (91-97); I series (93-94); I6 (91-97); I8 (91-97); NE 12 (91-97); NE-9b (93-97); S6 (90-97); S7 (96, 97); S1 (95-97); S2 (95-97); S11 (92-97). Surveys coastal plain (95-97); Haul road corridor lakes (90); I series lakes (97); Geomorphic trophic hypothesis 96, 97); NE14 (97), Toolik Lake Bays(97). Cation, anion, alkalinity data sets: Lakes sampled every 7-10 days: Toolik lake (1992-95); Lake N1 (92-95); Lake N2 reference and Treatment (92-95); Data sets for lakes sampled 2-4 times each summer: Lake E1 (92-95); I series (93-96); I6 (92-95); I8 (92-95); NE 12 (93-95); NE-9b (93-95); S6 (92-95); S1 (95); S2 (95); S11 (92-97). Surveys Fog lakes (92); N3,4,5 (92);NE lakes (92); Geomorphic trophic hypothesis (96);

Fish. Data sets include: size, weight, age, and location data for sculpin captured in a given lake in a given year (Toolik (1987, 1988); N1 (88); N2 (88); N3 (88); NE14 (88); S7 (88); S6 (88); S7 (88)); fish number, species, lengths, weights, sex, and maturity of fish captured in a given lake in a given year (Toolik (86-89); N1 (87-90); N2 (86-90); NE12 (86-90); NE14 (86-88); I8 (86-89); S6 (87-89); I6 (87); N3 (90); Fog (90)); fish number, recap number, species, lengths, and weights of fish captured in lakes near the Toolik Lake LTER site during the summer of 1992, 1993, 94, and 95.

Plankton: Bacteria, Microplankton, and Zooplankton. Data sets include: number of bacteria in Toolik Lake water column during June, July and August (92-95); cyanobacteria numbers (1996), biomass and numbers of microplankton (20-200um), including ciliated protozoans, rotifers and nauplii (90-95); zooplankton density for all the lakes sampled in 1977 and 1983-1996.

Isotopes. Data sets include: carbon and nitrogen stable isotope values for lake trout from 6 different Arctic lakes near Toolik; concentration of dissolved inorganic carbon (DIC) and $\delta^{13}\text{C}$ isotope value for lakes and rivers on North Slope from Brooks Range to Prudhoe Bay; isotopic values for carbon and nitrogen in biotic and abiotic samples from Lake N2.

Streams Data

Physical and Chemistry. Water temperatures from June through August for the Kuparuk River (1988-1997) and Oksrukuyik Creek (1989, 1991-1997). Discharge calculated from stage height measurements from June through August for the Kuparuk River (1987-1997) and Oksrukuyik Creek (1988, 1990-1997). Phosphorus, ammonium and nitrate concentrations measured at reference and nutrient-enriched stations of the Kuparuk River (1990-1997) and Oksrukuyik Creek (1990-1997). Bromide and/or rhodamine WT channel tracer studies: Kuparuk River (1994-1996), Oksrukuyik Creek (1995, 1996), Blueberry Creek and a tributary to Blueberry Creek (1994), Imnavait Creek (1995), and Inlet stream to Toolik Lake (1995-1996), and the Mouth of the Kuparuk River (1996). Hyporheic nutrients from pools and riffles in the Kuparuk River (1990-1992, 1995), Oksrukuyik Creek (1991, 1992, 1995 and 1996), and Blueberry Creek (1994). Bromide and/or Rhodamine WT hyporheic tracer studies Kuparuk River (1995, 1996), Oksrukuyik Creek (1995, 1996), Imnavait Creek (1995) and the Mouth of the Kuparuk River (1996). Vertical hydraulic gradient (VHG) measurements for the Kuparuk River (1995, 1996) and Oksrukuyik Creek (1995, 1996). Conductivity data for conservative tracer (NaBr) slug additions to the reference riffle in the Kuparuk River (1996) and Oksrukuyik Creek (1996).

Primary Production and Biomass. Sestonic and epilithic chlorophyll levels measured at reference and nutrient-enriched stations of the Kuparuk River (1983-1997), Oksrukuyik Creek (1990-1997) and Blueberry Creek (1994). Epilithic respiration, photosynthesis, chlorophyll a and nutrients from light/dark benthic metabolism chamber experiments of the Kuparuk River (1989-1996), Oksrukuyik Creek (1990-1996), Blueberry Creek (1994) and the Mouth of the Kuparuk River (1996). Point transects used to estimate epilithic bryophyte and macroalgal cover of the Kuparuk River (1992-1996), Oksrukuyik Creek (1993-1996), and Blueberry Creek (1994). Cover biomass measurements used to estimate bryophyte biomass in the Kuparuk River (1992, 1995 and 1996). Chlorophyll concentrations of *Schistidium agassizii* and *Hygrohypnum* spp. retrieved from the Kuparuk River (1996). Bryophyte growth data from the Kuparuk River (1992, 1993). Tissue phosphorus and nitrogen concentrations in the Kuparuk River (1992, 1995).

Fish. Growth of adult Arctic grayling measurements from June-August in the Kuparuk River (1986, 1988-1997) and Oksrukuyik Creek (1990-1997). Growth of young-of-the-year Arctic grayling from June-August in the Kuparuk River (1989-1997) and Oksrukuyik Creek (1989-1997). Long-term tag/recovery data of adult and juvenile grayling in the Kuparuk River (1985-1997) and Oksrukuyik Creek (1989-1997). Length, weight and tag data collected in the fall as fish entered the Kuparuk headwater lake

(1988, 1990) and in the spring as the fish leave the headwater lake (1987, 1989, 1990, 1992, 1995).

Insects. Drift collections: total numbers, measurements and species of insects taken from the Kuparuk River (1989, 1990) and Oksrukuyik Creek (1989-1992) drift samples. Data from the two drift distance experiments on the Kuparuk River in 1989. Benthic Collections: Total numbers, measurements and species of insects taken from the Kuparuk River (1989-1992, 1995) and Oksrukuyik Creek (1989-1995) rock scrubbings.

Terrestrial Data

Biomass/Production/Chemistry. Plant biomass measurements near Toolik Lake, Alaska for moist tundra, wet sedge, tall shrub, and dry heath. Harvests for select sites occurred in 1981-84, 1988, 1989, 1990, 1992, 1993, 1994, 1995, 1996, 1997. Some harvests include total nitrogen, phosphorus and leaf area.

Plant Species List compiled from D.W. Walker's 1989 relevés and from biomass quadrat harvests.

Plant Phenological and Growth. Leaf growth and phenology data from experimental plots near Toolik Lake and the long term data set of flowering abundance and nutrient content of *Eriophorum vaginatum*. The flowering abundance data are from observations at 34 sites, spanning 5.5 degrees latitude and 1050 m elevation in northern and central Alaska; collected since 1979 and annually since 1989.

$\delta^{13}\text{C}$ and Radiocarbon Dates. Percent moisture, percent organic carbon, bulk density, $\delta^{13}\text{C}$, $\delta^{15}\text{N}$, and radiocarbon content were determined at depth intervals in peat cores from the North Slope of Alaska

Soil: Properties, Chemical Composition and Extractable Nutrients. Extractable $\text{NH}_4\text{-N}$ and $\text{NO}_3\text{-N}$ (2 N KCl), $\text{PO}_4\text{-P}$ (0.025 N HCl) and pH (0.01 M CaCl_2); yearly nitrogen mineralization (1990-97), soil carbon, nitrogen and phosphorus content; and thaw depth (1990-97).

Trace Gases. Ecosystem respiration (ER: or CO_2 flux), methane (CH_4) fluxes and net ecosystem production (NEP) near Toolik Lake, Alaska, comparing effects of temperature, moisture and nutrients on tundra C balances.

Precipitation Chemistry. Unfrozen wet only and bulk precipitation for the summer months at Toolik Lake (1989-97).

Weather Data

Toolik Lake-Main Weather Station. This is the main Arctic LTER weather station at Toolik Lake (68 degrees 38'N, 149 degrees 36'W) with data collection starting in June 1988. Data collected include air temperature, wind speed and direction, relative humidity,

solar radiation, unfrozen precipitation, barometric pressure, soil temperatures, lake temperature, lake depth, and evaporation pan depth and pan water temperature.

Toolik Tussock Experimental Plots Weather Station. This site was started in 1990 to measure soil and air temperatures, wind speed and direction, relative humidity, solar radiation, and unfrozen precipitation in the experimental plots near Toolik Lake.

Sagavanirktok River Weather Station. This site was first started in 1986, recording data during the summer months. In summer of 1993 the station was maintained year round. Data collected include air temperature, wind speed and direction, relative humidity, solar radiation, unfrozen precipitation, and soil temperatures.

Land-Water Data

Dissolved Organic Carbon (DOC). Concentrations for lakes, streams, and groundwater from 1989-1990 and 1992-1997 field seasons (ca. 8800 samples).

Dissolved Gases. Partial pressures and aqueous concentrations of carbon dioxide and methane in lakes, streams, and groundwater from 1990 and 1992-1997 field seasons. Approximately 3500 samples from sites near Toolik and in the Kuparuk Basin.

Water Chemistry of lakes, streams, groundwater, and precipitation for 1989-1997 field seasons. These data include some physical data (e.g., temperature), alkalinity, nutrient, and major and minor ion concentrations (ca. 4000 samples).

Thaw Depths measured twice annually (July 2nd and August 11th) at 102 sites in a small watershed located in the Tussock Experimental watershed. Survey has been conducted from 1990-1997.

Discharge calculated from the stage height and flow at the Tussock Watershed weir from 1991 to 1997. These data are reported for hourly intervals.

Isotope Data of carbon and nitrogen stable isotopes of algae, aquatic macrophytes, invertebrates, zooplankton, and fish from 6 lakes (1988 and 1989, ca. 50 samples).

GIS Data

GIS Data. Donald (Skip) Walker, INSTAAR, University of Colorado has ARC/INFO coverages of ARC LTER and NSF/ARCSS/LAII-funded study sites available online (see www.colorado.edu/INSTAAR/TEAML/atlas/). Maps of Alaska North Slope study site (1:250,000 scale) and Toolik Lake study site (1:25,000, 1:5000, 1:500 scale) are available. Data layers include: vegetation, geomorphology, hydrology, elevation, soil carbon, percent water, and geology.

GIS Data. Anne Hershey, University of Minnesota Duluth, has maps relating to the project on geomorphic control of fish distribution which was centered around Toolik

Lake. Figures and maps include: a geomorphic decision tree for landscape control of fish distribution.; maps on how the distribution of fish species determines benthic and pelagic invertebrate communities; maps on how the landscape factors, which are quantifiable, determine distribution of fish species; and maps on how the trophic structure of lakes is predictable on a large scale based on landscape-level criteria. The address is www.nrri.umn.edu/nrri/toolik/image.html

Theme, Conceptual Framework, Research, Regionalization, Synthesis

The New Theme of Predicting Future Ecological Change

Unlike ecosystems at most LTER sites, the Toolik Lake site has apparently changed little for many thousands of years. The primary evidence comes from pollen records in lake sediments (Eisner and Colinvaux 1992) that indicate an unchanged vegetation since about 6500 yr B.P. when alder was added to the birch. Not only is the vegetation intact over this period but the fauna of the large mammals, dominated by the caribou, wolf, and grizzly bear, is also intact and caribou populations in 1997 were the highest in many decades (R. White, personal communication). The same is true of the aquatic environments; for example, lakes and streams a few kilometers from the road have undisturbed lake trout and grayling populations. Recent studies of airborne contaminants (Ford et al. 1995, Wilson et al. 1995) show that this site has extremely low levels of heavy metals and pesticides; material from the interior of Alaska evidently does not cross the Brooks Range to the south and material transported from northern Europe is minimal compared to that deposited closer to Europe, for example, in the Canadian High Arctic. One product of northern Eurasia, the sulfate aerosols making up arctic haze (AMAP 1997), has undergone a drastic reduction in the past decade (NOAA data). Thus, while no place in the northern hemisphere is entirely free of airborne contaminants, this site is as close to pristine and unchanged in recent time as it is possible to find.

In contrast to this ecological stability over the past centuries, the climate of northern Alaska changed remarkably over the past 30 years; the temperature of the region has increased by more than 0.5°C per decade based on both the standard long-term climate station records and on radiosonde records. No one knows if this warming is a part of the predicted 3-5 degree change predicted by GCM models (Maxwell 1992) but it is known that other areas of the Arctic, such as the Chukotka Peninsula across the Bering Strait from Alaska, have either not changed or have become colder. Based on several types of observations, there appears to be a biotic response to this regional warming. First, Oechel (personal communication) notes that the moss vegetation at Barrow has nearly disappeared in the 25 years since the IBP project. Second, D. Walker and co-workers (personal communication) has found that the NDVI (a satellite-based indicator of plant biomass) has increased in northern Alaska. Third, the detailed study of vegetation communities at Toolik by M. Walker (personal communication) shows a reduction in moss cover and an increase in shrubs over a six year period. Accordingly, the goal of the LTER project will change slightly to emphasize our interest in predicting the future ecological characteristics of the site. This prediction will be based upon our knowledge of

the controls of ecosystem structure and function as exerted by geologic factors, climatic factors, biotic factors, and the changes in fluxes of water and materials.

Goal. The goal of the Arctic LTER project is to understand the present and predict the future characteristics of arctic communities, ecosystems, and landscapes based on knowledge of the controls of ecosystem structure and function by

- *physical factors (glacial history, geomorphology)*
- *climate factors*
- *biotic factors (resources, grazing, predation)*
- *fluxes of water, nutrients, and organic matter among components*

Conceptual Framework of The Arctic LTER Site

The key to predicting the future ecology of tundra, streams, and lakes lies in understanding the present controls of ecosystem structure and function. Once these are known, mathematical models can be used to predict many of the characteristics of communities, ecosystems, and landscapes. In [Fig. 7](#), which is the generic conceptual model for the entire tundra system, the structure and function with their sub-elements are at the center of the framework. The major forces driving the ecosystem are at the four corners, the physical setting, climate, biota, and fluxes in, through, and out of the system. The factors controlling the important processes related to the drivers and affecting the structure and function of this particular ecosystem are shown in the boxes along the arrows.

Physical Setting. The arctic location of the site is in the zone of continuous permafrost. This important feature both limits the plant roots to the ~0.5 m of the active layer that thaws each summer and effectively prevents any downward water loss. Despite the scant precipitation, the tundra is moist and streams abundant. The thickness of the active layer will diminish when an insulating litter layer builds up as demonstrated by fertilization experiments. Although the permafrost has warmed in the past decades (Osterkamp 1994), it will not melt in this region during the next century. Differences in the active layer thickness over the landscape are caused mainly by differences in vegetation and water movement, both related to geomorphology and soil texture.

Major differences across landscapes on the site result from two ages of glacial till, one 10,000 years old and one 100,000+ years old. In the younger regions, the pH of the soils is close to neutral, small lakes are abundant, and the smallest scale of the drainage network is undeveloped. In contrast, the older material is sufficiently leached that the pH is acid and mosses are abundant. The drainage channels are better developed leading to more plant biomass, particularly of shrub willows. Both slope and site age affect the structure of the stream network; overall the streams vary from 1st to 4th order.

The ancient and highly metamorphic base rocks of the Brooks Range determine the chemical composition of the glacial till. This, along with the climate, leads to a low rate of weathering and low rates of phosphorus availability, cycling, and transport into

streams and lakes. This, in turn, is expressed in the low rates of terrestrial and aquatic plant production, one of the functions of the ecosystem. When the iron-rich sediments reach the lakes, they strongly retain PO_4 and thus restrict productivity.

Topography of the site determines the stream gradient; in the extreme case the gradient is so steep that fish can not reach an upstream lake. Along with the underlying glacial till, the topography controls the presence of springs which are nutrient-rich, highly productive, and serve as extremely important overwintering locations for young fish.

Climate. The temperature during the 3-month summer is the main control of the vegetation type with precipitation, expressed as soil moisture, a secondary control. Soil moisture and temperature control the decomposition rate but above a certain level of soil moisture the decomposition rate is slowed as anaerobic conditions develop. Microbial decomposition continues beneath the snowcover down to $\sim -7^\circ\text{C}$; this can account for up to half the total soil respiration. The decomposition contributes to soil gases, mainly CO_2 and CH_4 , and to the mineralization of organic matter to inorganic nutrients and DOC.

The amount of snow (less than 1 m) depends on precipitation but its distribution over the landscape depends on wind and geomorphology; shrubs and valley bottoms trap snow and hill tops may be bare. The duration of the 8-9 month long snow cover depends on the radiation balance and air temperature in May and June. Duration affects photosynthesis which does not begin until snow disappearance, typically in early June. By this time, nearly half the annual PAR has reached the site. The variability of snow and summer precipitation controls stream discharge which in turn controls production of stream insects and fish.

The wind, solar radiation, and temperature combine to cause a quick stratification of lakes after ice-out. A winter oxygen debt may not be made up. Increasing temperatures will reduce the habitat for cold-water fish such as the top predators, the lake trout and char, and increase their food needs by many-fold.

Biota and Their Activity. In the tundra, most of the nutrients for productivity come from the recycling activity of soil microbes. This, in turn, may be controlled by root production and exudation. In contrast, aquatic primary productivity is controlled by the rate of supply of nutrients from outside the stream or lake.

Herbivores control the species of the terrestrial flora but do not affect the primary productivity. In lakes the herbivores (zooplankton) are so rare that they exert little control through their grazing. Top-down control of algae is found in streams. In addition, the lakes receive so much allochthonous DOC that a productive microbial food web is operative, consisting of bacteria and their predators, the heterotrophic nanoflagellates.

Lake food webs have lake trout and char at the top. These large predators control the species composition and abundance of the fish, such as grayling and sculpin, beneath them in the food web. These fish plus the young trout and char control zooplankton abundance and, in some cases, the species. When all lake trout are removed, then large-

bodied *Daphnia* thrive. Another predator, the copepod *Heterocope septentrionalis*, can eliminate small-bodied zooplankton species. Sculpin and lake trout, when present, regulate the density and species composition of the snail and chironomid benthic communities.

Stream food webs have a single species of fish, the arctic grayling. These are primarily drift feeders. The top-down control within the food web comes from the insect scrapers who continually remove the chief primary producers, diatoms, from the surface of stream rocks. Extra nutrients allow the algae to outgrow their grazers for a year or two but the herbivores quickly increase their activity and regain control. Long-term addition of nutrients to streams allows mosses to become dominant; the rate of productivity and the habitat is completely changed.

Soil, stream, and lake biota and their activities transform organic matter and liberate inorganic nutrients. When the supply rate of organic matter is high, as in the soil, the interaction of vegetation and decomposition produces CO₂ and CH₄ that reaches the atmosphere either directly by diffusion from the soil or indirectly after it has been transported into the streams and lakes.

Land-Water-Atmosphere Fluxes. The interaction of precipitation, evapotranspiration, and topography causes water movement through the soil to streams and lakes. This allows the transport of soil gases, nutrients, and organic matter; the amount of material transported is likely controlled mainly by the quantity of water. Because the soil water is supersaturated with CO₂, the streams and even the lakes of this region are supersaturated and are a source of CO₂ to the atmosphere except in artificially fertilized lakes. The amount moved through this aquatic-atmosphere link is equivalent to 20% of the total soil respiration; this plays a significant part in the carbon source/sink role of the tundra. The actual transfer from the water surface to the atmosphere is controlled by the wind and the net radiation.

Variations in the fluxes of materials from different parts of the landscape into streams are caused by differences in vegetation ([Fig. 8](#)) and soil processes. It is likely that pH and age of the glacial till play an important role but only a little is known. The nutrients transported in are quickly used by the biota: a cycling distance of 900 m for NH₄ was measured in a large stream. These ecosystems are nutrient limited and release only small amounts of nutrients downstream to the ocean.

Research Approaches of the Arctic LTER Project. The goal of understanding the present and predicting the future of a complete ecosystem is an ambitious one that can only be approached with a long-term plan of research. The elements of the plan include:

1. long-term monitoring and surveys of natural variation of ecosystem characteristics in space and time.
2. experimental manipulation of ecosystems which are maintained and measured for decades
3. synthesis of results through modeling at ecosystem and watershed scales

4. feedback from the synthesis and modeling to identify gaps in knowledge.

Note for Reviewers. Process-based research, monitoring, and experiments have been carried out at this site since 1975 (the hundreds of publications are listed on the Arctic LTER WWW). Many of the controls of processes affecting the structure and function of the ecosystem components are known and will not be studied in detail during the next six years. The sections describing the terrestrial, stream, lake, and land/water research that follow take up the continuing and new research that we judge vital to improve our understanding and predictive power.

TERRESTRIAL

Introduction. Terrestrial research at the Arctic LTER includes experimental and descriptive studies of the effects of the physical setting (geology/geomorphology), climate, biota, and fluxes of water and nutrients on tundra ecosystem structure and function (Fig. 9). The physical setting controls include effects of variations in soil acidity and topography, which can cause dramatic local and regional variation in vegetation composition, productivity, biomass, and element turnover (Billings 1973, Gibling et al. 1991, Shaver et al. 1996). Climate is critical in extreme environments such as the Arctic, where growing seasons are often less than 100 days and where variations in the timing of snowmelt can significantly alter the time available for biological activity. Radiation inputs are always low, and low temperatures have significant effects on element cycling (Chapin 1983, Shaver and Jonasson in press). Biotic effects on arctic ecosystem structure and function are mediated through low overall species richness of flora and fauna (Gough et al. submitted), differences in the distribution of plant functional types or growth forms (Billings and Mooney 1968, Shaver et al. 1996), and trophic interactions such as the reciprocal effects of grazing on plants and herbivores (Batzli et al. 1980, Jefferies et al. 1994). Finally, fluxes of water and nutrients into, out of, and within arctic ecosystems (Gold and Bliss 1995, Nadelhoffer et al. 1991) are closely related to variation in ecosystem structure and function.

The terrestrial research design incorporates all four of these categories of controls, through a combination of comparisons among sites that differ in their physical setting (e.g., their geology/geomorphology) and biota with long-term manipulations of climate and nutrient inputs in each of these different sites (Table 1). For example, over the past 15 years we have maintained a series of experiments in which 4 contrasting tundras, dominated by different mixes of plant functional types, were subjected to identical manipulations of nutrient inputs, air temperature, and shading (light). Comparisons among treatments within each tundra type have taught us a great deal about the roles and interactions of climate and nutrient fluxes (Chapin et al. 1995, Shaver et al. 1998). Additional comparisons of the responses of contrasting plant functional types to a common suite of manipulations in different sites have taught us how differences in species function affect overall ecosystem characteristics (e.g., Bret-Harte submitted).

In the next 6 years, we will maintain the existing experiments, harvesting them occasionally. Because these ecosystems continue to respond to the treatments, we have

gained new insights about ecosystem regulation with each harvest. However, our focus in 1999-2004 will be on a new series of long-term experiments, specifically focused on herbivory (biota) and variation in soil acidity (geology/geomorphology). We also will continue long-term monitoring of plant growth and flowering in relation to weather variation (Shaver et al. 1986, Shaver and Chapin 19956). With complementary funding from related grants, we will continue process studies (below). Simulation modeling and cross-site comparisons will be a major, continuing effort.

1) New Experiments

Herbivore exclosures: In July 1996 we set up herbivore exclosures in acidic tussock and dry heath tundras. These exclosures were established on prerandomized LTER experimental plots set up in 1987, with $n=4$ in tussock tundra and $n=3$ in dry heath. There were two, nested levels of exclosure (microtine exclosures nested within caribou exclosures), combined factorially with NP fertilizer addition. We will harvest these plots at least once and possibly twice during the 1999-2004 period (ideally in 1999 and 2003). We hypothesize that herbivores play an important role in controlling tundra species composition, but are unimportant as controls on productivity or nutrient turnover at 1-10 year scales. We also hypothesize that herbivores induce changes in species composition more rapidly under fertilization, but that fertilized plots with or without herbivores will converge to the same species composition after about 10 years.

Non-acidic tundra: In July 1997, we established new experiments in non-acidic tundra on the northwest shore of Toolik Lake, one in non-acidic tussock tundra and one in non-acidic, non-tussock tundra. These experiments are identical in design to the existing experiments in acidic tussock tundra and other sites that have been maintained since the start of the LTER project (Chapin et al. 1995, Shaver et al. 1998). Three experimental blocks were set out at each non-acidic site. In both sites, factorial N&αχυτε; P fertilizer treatments were applied, using the same fertilizers and rates of application as in the existing sites. In the non-acidic tussock site, we also set up a factorial greenhouse &αχυτε; NP experiment identical to earlier experiments in other sites. In both the tussock and the non-tussock sites, extra (untreated) plots were set out for future treatments (e.g., liming/acidification). We will harvest these plots at least once and possibly twice during the 1999-2004 period (ideally in 2000 & 2004). We will compare the response of these non-acidic tundras to the response of acidic tundras harvested previously.

Response to Liming: In 1998 we will set up liming experiments in acidic tussock tundra to reduce soil acidity. In 1999 we will add elemental sulfur to non-acidic tundra to increase soil acidity. These experiments will focus on links between soil acidity and ecosystem characteristics such as species diversity, productivity, decomposition, and N and P cycling over the next 6 years. The liming/acidification plots will be harvested once during the 1999-2004 period (ideally 2001), but will be maintained for harvest in 2005. The harvests will be coordinated with a harvest of a long-term liming experiment at the Sagavanirktok River toposequence, begun in 1985 ([Table 1](#)).

2) Ongoing Experiments. In 1988 we established factorial manipulations of N, P, air temperature, and light in four tundra types surrounding Toolik Lake. Responses of acidic tussock, wet sedge, and dry heath have already been documented; riparian shrub tundra, will be harvested in 1998. These experiments will be maintained to allow sampling by cooperating projects, and eventually will be harvested again. We also will maintain long-term fertilizer plots in tussock tundra (begun in 1980) and fertilized and limed plots at Sagavanirktok River (begun in 1985). The limed plots will be sampled in coordination with work on the new pH manipulations at Toolik Lake. The 1980 fertilized plots will be harvested once in the next six years, probably in 2000 (Year 20 of treatment). After this harvest, fertilization will continue on only half of each 5x20 m plot, and the recovery of the other half of the plot will be monitored.

3) Process, Species, and Community-level Studies. Several independently-funded projects coordinate their data gathering with LTER-supported research, usually by additional sampling of LTER experiments. The LTER experiments are designed to accommodate this additional sampling, mainly by making the treatments cover a large area, and by incorporating extra untreated plots (for additional sampling or future treatments). Typically, the LTER-supported harvests provide the ecosystem-level budgets that provide context for evaluation of more focused process- and species-level data collection. The LTER funds are also used to support small, focused pilot studies that are intended to expand the overall scope of research and to fill gaps in the research program.

Plant diversity and species effects on ecosystem function: This project, supported by NSF-OPP, is part of the International Tundra Experiment (ITEX) and will continue at least through 1999. By sampling LTER experimental plots, we aim to understand and isolate the role of species in controlling ecosystem function and response to disturbance. We hypothesize that RESOURCES (element stocks and cycling rates) control long-term NPP and organic matter accumulation; but species composition is not important to average NPP and turnover along large gradients of resource availability. However, SPECIES do determine the RATE of response to changes in resources, especially the initial response. Examples of this work are Donie Bret-Harte's work on shrub growth and Laura Gough's work on diversity/productivity relationships (Bret-Harte et al. submitted, Gough et al. submitted).

Soil-plant interactions: An ongoing theme of our research has been the constraints on C cycling imposed by C/N interactions, and variation in those constraints with topography (geology/geomorphology), species composition (biota) and nutrient inputs (fluxes). Current foci are: (1) C respiration/N mineralization interactions ([Fig. 10](#)), and (2) below-ground C inputs, as root production and root exudation (NSF OPP 96 15563). In collaboration with other NSF-DEB and NSF-OPP projects, harvests of our plots provide biomass and production measures that complement process-level measurements of soil respiration, N mineralization, and the distribution and movement of stable isotopic tracers (¹³C and ¹⁵N) through plants and soils (Giblin et al. 1991, Nadelhoffer et al. 1991, Nadelhoffer et al. 1995, Shaver et al. 1998, Johnson et al. 1996 and submitted).

Soil biota and community structure: A new community-oriented initiative for 1999-2004 is to determine effects of our long-term experiments on soil invertebrates. In 1998 we have invited Drs. Dave Coleman and John Moore to come to Toolik Lake to help develop techniques for sampling and describing soil communities across the full suite of sites and experimental manipulations. By 2000, we aim to have a project in place that will tell us how geology/ geomorphology, fluxes, climate, and biota interact to determine soil biotic diversity and major characteristics of soil community composition (Moore and Hunt 1988; Moore et al. 1989, 1993; de Ruiter et al. 1995).

4) Monitoring Plans, 1998-2004

Weather and atmospheric deposition: We will continue to monitor these variables and to maintain the LTER climate data base. (See Data Sets Section)

Plant growth, flowering, and soils: We will continue to track annual variation in flowering and growth of *Eriophorum* along the Dalton Highway and of other species at 5 sites on the North Slope. We will continue to monitor soil N mineralization using buried bags at Toolik Lake. (See Data base section)

5) Modeling, Synthesis, and Scaling up in Space and Time. The LTER project and its data management/data archive capabilities are used to facilitate synthesis of terrestrial research in several ways. One way is by direct integration of diverse data sets, all collected from the same sites and experiments. We have used this approach successfully in the past to construct and compare C, N, and P budgets for vegetation and whole ecosystems (Shaver and Chapin 1991, Shaver et al. 1998). The LTER effort is structured to maximize direct, empirical synthesis of data. Priority topics for this kind of empirical synthesis include:

Structure and function of contrasting arctic ecosystem types. As part of the Toolik synthesis volume, we will compare community structure and the C, N, and P budgets of the main ecosystems of the area. The focus will be on differences in response to manipulation of a range of ecosystems all manipulated in the same way.

Ecosystem response to similar experiments in Sweden and Alaska: For the past several years, experiments similar to ours has been underway at Abisko, Sweden, and on Svalbard. A cross-site analysis of results will begin in the summer of 1998 and continue through at least 2000. We want to know if the Toolik results can be generalized across the whole arctic region. This exercise and the Toolik synthesis will work toward a general conceptual model of arctic ecosystems like the one we published in *BioScience* a few years ago (Shaver et al. 1992).

Growth and flowering of arctic plants. The ITEX project involves comparative data collected at over 25 sites throughout the Arctic. Our collaboration with this group, which has led to 2 recent papers in *Global Change Biology* (Molau and Shaver 1997, Shaver and Laundre 1997), will continue with the aim of determining the relative sensitivity to

climate change and annual climate fluctuation of selected arctic plant species at multiple sites.

Modeling. The LTER data base is a particularly rich source of data for development and validation of computer models like GEM (The MBL General Ecosystem Model). We will continue to use GEM for interpretation of experimental results and for long-term extrapolation. Model development is supported by independently-funded grants, with data supplied by the LTER. Priority topics for the next 6 years include: a.) develop a new Model of Arctic Decomposition based on C-N and C-P stoichiometry of plant litter, soil organic matter, and soil microbes ([Fig. 11](#)), In conjunction with; b) further develop landscape and watershed models of C, N, P, and water (with ARCSS OPP96-22157); c) further develop GEM (McKane et al. 1997a, b) and other models of NPP (Williams et al. 1997), element cycling, and the role of over-winter storage of nutrients within plants (with LAII OPP97-32281 and SIMS-ARCSS OPP96-14038); d) further development of the MEL (Multiple Element Limitation) model to explore the role of species composition on nutrient cycles and productivity (with DEB 9509613).

STREAMS

Introduction. The goal of the streams research is to understand how the structure and function of streams in the arctic landscape evolve as climate and inputs from land change over time. Understanding how biogeochemical processes and trophic structure vary as a function of stream size and landscape position are central to understanding the overall function of the stream network (Allan and Flecker 1993, Billen et al. 1994, Naiman et al. 1995, Townsend 1996). The structure and function of arctic streams is controlled by geomorphology, climate, fluxes of resources from land and by biotic interaction among components of the stream community ([Fig. 12](#)). Our research has demonstrated these 4 factors are all important controls on arctic stream processes and populations. For example, climatic variation in summer precipitation controls stream discharge which in turn controls stream insect and fish production (Deegan et al. submitted, Hershey et al. 1997). Landscape geomorphology dictates the presence of springs which are nutrient-rich, highly productive habitats (Craig and McCart 1975). Long-term fertilization experiments have demonstrated strong stream responses to increased nutrient inputs, including increases in primary production, insect abundance and fish production (Peterson et al. 1993, Harvey et al. in press). The response of the stream ecosystem to different combinations of geomorphology, climate and fluxes from land is moderated by biotic interactions such as top-down control by consumers (Gibeau and Miller 1989) and competition for space by primary producers (Bowden et al. 1994). Our proposed experiments and models are designed to understand the control of ecosystem processes and populations by all 4 of these factors across a wide variety of stream types and to develop an integrated whole watershed stream network model.

Stream Experiments Long-term fertilization experiments have demonstrated the importance of nutrient inputs from land (Fluxes in [Fig. 12](#)) to river ecosystem structure and productivity. Dissolved phosphate and ammonium were added continuously to two streams each summer from 25 June to 15 August. Measurements included dissolved

nutrients, algal & moss biomass, primary productivity, insect abundance, and fish abundance & productivity (Peterson et al. 1993, Harvey et al. in press, LTER methods on web site). As summarized in the Prior Support section, during the first few years of fertilization, we saw an increase in the overall productivity in the fertilized reach compared to the control reach of the Kuparuk River (Fig. 3, Hershey and Hiltner 1988, Deegan and Peterson 1992, Peterson et al. 1993). Response of a second river, Oksrukuyik Creek, to fertilization followed the same basic patterns observed in the Kuparuk River (Fig. 3, Harvey et al. in press). Manipulations of adult and YOY fish indicate that production in these rivers is largely controlled by bottom-up nutrient supply and flood disturbance (Deegan et al. 1997, Golden and Deegan in press). Over a period of about 8 or 9 years, the dominant primary producer shifted from diatoms to moss in the fertilized reach of the Kuparuk River (Bowden et al. 1994). The change in primary producer and habitat structure has also changed the abundance and distribution of insects (The Streams Bryophyte Group, submitted). In 1997, adult fish in the fertilized reach of the Kuparuk River did not grow any faster than fish from the control reach which may indicate that the long-term change in food web structure from diatoms to moss may be adversely affecting fish production.

We propose to continue the long-term fertilization of the Kuparuk River. We need to know if the fertilized reach has reached a new equilibrium or if major new species shifts or changes in productivity will occur. In addition, we need to understand if and at what rate streams return to a state similar to that found prior to a major disturbance (Naiman et al. 1995). Recovery of streams from disturbance is thought to be rapid, however, most observations to support this view have not been from a whole river or even stream reach perspective (Bunn and Hughes 1997). Descriptive studies from large scale natural disturbances indicate that recovery may be much slower (Mackay 1992, Wooten et al. 1996). We propose to follow the recovery from fertilization in Oksrukuyik Creek over the next 6 years.

Our understanding of the factors controlling productivity in smaller arctic streams is not as well developed as for larger streams. In contrast to the larger rivers, lateral linkages to riparian corridors may be more important in smaller streams (Townsend 1996). Despite the small stature of riparian willows in the arctic landscape, productivity in these small ($\sim 0.1\text{-}0.5\text{ m}^3\text{ s}^{-1}$) and narrow (<1 to 2 m) streams may depend on inputs of leaves and insects from terrestrial systems. In a small stream near Toolik (E1), we found higher densities of shredder insect species than in the Kuparuk or Oksrukuyik Creek, indicating that leaf inputs may be an important source of organic matter to small streams as predicted by the river continuum concept (Vannote et al. 1980).

We propose new experiments to test the importance of terrestrial inputs relative to autotrophic production on productivity in these small streams through P fertilization and litter exclusion experiments. In the P fertilization experiment, we will replicate the ongoing Kuparuk fertilization experiment. In the terrestrial litter exclusion experiment, we will prevent leaf litter from entering the stream by stretching mesh netting over the stream and under the canopy (Wallace et al. 1997). If leaf litter forms the base of the food

chain, we expect the production of shredders and other insects, as well as fish, to decrease.

Extensive Stream Surveys. The geomorphology of the landscape has an impact on many functions of stream ecosystems ([Fig. 12](#)). For example, arctic streams derive waters from glaciers, springs and tundra runoff. The water from these sources is sufficiently different that these three stream types transport very different solute and particulate loads and support very different communities of organisms (Lock et al. 1989, Craig and McCart 1975). Glacial streams are the least productive because the fine sediment abrades and smothers stream communities. Springs are the most productive because of the relatively high nutrient levels, stable water temperature and year-round discharge. The locations of glaciers and springs are determined by the geomorphology of the landscape.

Over the past several years, the streams program has expanded its focus to include extensive sampling of mountain and spring streams ([Fig. 13](#)). One goal is to build a body of information to estimate the transport and processing of nutrients and organic matter at the whole watershed level. A second goal is to determine the relationships between stream geomorphologic setting and community structure. These surveys are designed to test a geomorphic-trophic hypothesis for arctic streams which states that: 1) the quantity of nutrients entering stream reaches is related to landscape geomorphology and 2) nutrient inputs to stream reaches in large measure control the structure and function of the stream ecosystem. Long-term fertilization studies, extensive surveys, and ^{15}N experimental tracer studies have yielded the following observations which support the hypothesis. First, nutrients control community composition and productivity of primary producers in the Kuparuk River and in Oksrukuyik Creek (Peterson et al. 1983, 1985, 1993, Harvey et al. in press). The enhanced moss coverage in the fertilized reach of the Kuparuk River parallels that found in spring streams and illustrates that mosses are characteristic of high nutrient conditions (Bowden et al. 1994). Second, consumers are food limited, responding with either increased density or faster growth to the enhanced productivity (Hershey et al. 1993, Deegan and Peterson 1992, Golden and Deegan in press). Thus we believe that geomorphology controls inputs of water and nutrients and these in turn influence community composition and ecosystem function.

We know that areas where groundwater enters streams are high nutrient environments, and support high algal, moss, and invertebrate biomass and productivity. Our surveys indicate that the locations of these areas are predictable on a regional scale using landscape-level criteria such as hillslope topography, vegetation physiognomy, valley floor topography and location terminal moraines. Our GIS database of geomorphology, vegetation coverage and watershed delineation for the Toolik Lake and Upper Kuparuk region can be used to predict stream characteristics (Database can be viewed on our web page.) To test our hypothesis we need to expand the GIS to include additional watersheds and to incorporate our biologic data as additional layers. We propose to sample 6 additional sites per year measuring nutrient concentrations and indicators of biotic productivity, such as algal, moss, invertebrate and fish biomass. We will use a patch dynamic framework for habitats (Pickett and White 1985, Frissell et al. 1986, Hawkins et al. 1993, Imhoff et al. 1996) expanded to include ecosystem processes and link this to a

landscape level classification (Turner and Dale 1990, Schlosser 1991, Poff 1997) to test the geomorphic-trophic hypothesis for stream productivity on a regional scale.

Intensive Stream Surveys. Intensive studies of the function of stream reaches are required to provide in-depth knowledge of nitrogen and carbon processing in the stream and river network. These studies focus on documenting the biotic structure (Fig. 12) and on quantifying the retention, transformation and export of nutrients and organic matter by representative stream reaches. We propose to add ^{15}N enriched ammonium to a different stream reach each summer (Hershey et al. 1993, Peterson et al. 1997). A continuous 4-week tracer addition will be accompanied by intensive sampling of standing stocks of C and N in the water, detritus, primary producers, insects and fishes (Fig. 14). The spatial and temporal patterns of tracer ^{15}N distribution provide estimates of the rates of nitrogen processing and transformation. At the same time, studies of nutrient seepage and hyporheic exchange (Edwardson 1997) allow us to develop the N budget for the reach.

Over time, we will obtain the information required to calibrate a watershed scale N model of processing in streams and rivers. Thus far, we have performed tracer addition studies on first to sixth order tundra streams. Now we propose to study mountain, glacial and spring streams to extend this kind of information to stream types typically found in watershed on the North Slope.

Modeling. The goal of the stream modeling activity is to produce 2 linked models which: 1) predict the processing, retention and export of carbon and nitrogen within the stream network of the Arctic LTER and; 2) predict the change in community structure with position in network and in response to disturbance. The information base for the model will include the long-term monitoring data (Fig. 3), the long-term fertilization results, the intensive stream reach and $\delta^{15}\text{N}$ tracer studies conducted within the watershed (Peterson et al. 1997), extensive surveys, and numerous experimental studies of stream processes (e.g., Deegan et al. 1997, Hershey et al. 1997). The stream reach model which was developed based on the Kuparuk River (Peterson et al. submitted) computes the uptake, retention and transport of N (Fig. 14). This model now guides comparisons of N cycling at 12 sites from the tropics to the arctic (Hall et al. in press) and forms the basis for our new stream network initiative.

We propose to modify this stream model to address two issues: biogeochemical processing and transport, and changes in stream community structure in response to disturbance. The first task will be to simplify the model to contain only those compartments necessary to simulate transport, uptake and retention for the stream network. This can be accomplished initially with a statistically-based approach where streams of similar size (1st order) are clustered and then export water and materials to the next larger size (2nd order) and so on (Billen et al. 1994). The second task will be to develop a model of community structure that links to the biogeochemical transport model. We will use the geomorphic-trophic surveys to develop the community model. Once linked to the biogeochemistry model, we will be able to examine if ecosystem processes (such as N retention) and community composition (such as fish abundance) have the same patterns with respect to position within the landscape. For example, Morin

and Naiman (1990) found that both fish production and efficiency of C processing were maximal in streams of fourth to fifth order. The third task is to develop a spatially explicit model where each reach is treated independently in the context of its geomorphic setting. The existing GIS data base developed under prior LTER funding for topography, soils, vegetation, lakes and the stream network makes taking the next steps to a landscape level stream network model possible.

Testing Long-Term Model Predictions. Streams respond to the quality and quantity of input of water and materials from land through changes in the transport and processing of nutrients and through changes in their community structure. An analysis of climate change affects on freshwaters of the Pacific coastal mountains predicts substantial effects on runoff and aquatic productivity (Melack et al. 1997). If long-term climate warming eventually changes precipitation inputs and plant cover on the tundra landscape, the inputs to streams will change, but what exactly would these changes be and how would they affect stream ecosystems of the arctic landscape? How can we test our predictions of long-term changes in the stream network without actually waiting for climate to change?

We propose to sample catchments south of Toolik that now have a vegetation cover and climate regime similar to that predicted to occur in tundra regions within a few hundred years as a result of climate warming. This 'space for time' substitution represents one way to link land cover changes caused by climate trends to stream ecosystem characteristics. For example, the Toolik tussock tundra landscape is predicted to be replaced by shrubby tundra and sparse boreal forest under projected greenhouse warming. Intensive sampling of stream community structure, nitrogen cycling, primary and secondary productivity and watershed export of organic matter and nutrients will be carried out in drainages currently dominated by shrubby tundra for comparison with parallel measurements on tussock tundra watersheds.

LAKES

Introduction. The structure and function of arctic lake ecosystems is controlled by climate, the physical setting, fluxes of nutrients from land and streams, and biotic interactions between species of the lake communities ([Fig. 15](#)). For example, geomorphology may determine lake sediment chemistry and the ease with which fish can invade a lake. In lakes in temperate zones (Schindler et al. 1987), fluxes of N and P from lake sediments may supply an appreciable portion of the nutrient requirements for primary producers. However, at least some arctic lake sediments behave differently as the N-2 fertilization experiment revealed that Lake N-2 has a very high capacity for phosphorus retention ([Fig. 16](#)). The reason for this is high quantities of iron oxides in the surface layers of the sediments (Cornwell and Kipphut 1992). However, not all lakes in the area share these characteristics (Giblin et al. 1990). Thus it is important to understand how lake age and watershed geomorphology influence sediment chemistry and, hence, lake productivity.

Geomorphology can also determine fish fauna in lakes because streams control fish invasion into lakes. Lake trout are particularly poor invaders of lakes (Hershey et al.

submitted). Previous studies (Hershey 1990, Merrick et al. 1991, McDonald and Hershey 1992, O'Brien et al. 1979) have shown that lake trout, when present, dominate the food webs of larger arctic lakes by feeding heavily on benthic organisms and by controlling the distribution of small pelagic fishes. Char appear to structure lake food webs in a similar manner to lake trout. However, neither species is common in arctic lakes because high gradient outlet streams preclude invasion and shallow depth and small area provide insufficient habitat. Because of the major role of these fish in structuring arctic lake food webs, it is important to know what lakes are accessible and which species will prevail.

Climate is another important determinant of lake function and structure. Kerr (1998) illustrates the potential for change as the year 1997 was the warmest year of the 20th century and the warmest five years of the century have all occurred since 1990. If there is climate change, then impact on arctic lakes could be profound. One reason is that arctic lakes mix very little after ice out (LaPerriere 1981) so that any winter oxygen debt will not be made up from the atmosphere and these lakes will be vulnerable to low-oxygen fish kills. While a warmer climate might lead to better spring mixing. However, recent modeling of arctic lakes (see modeling) predicts arctic lakes will be more vulnerable to eutrophication as increased epilimnetic temperatures cause increased primary productivity and reduced hypolimnetic volume. Increased lake temperature could also have grave impacts on young-of-the-year (YOY) lake trout. Using a bioenergetics model for YOY lake trout we calculated (McDonald et al. 1996) that with a 3°C increase in temperature these fish would need to consume 8 times more food to achieve the same end of the year size as in the before-warming conditions. Thus we need a north-south temperature gradient survey of lakes to study the possible impact of arctic warming (see Alaska Transect, Regionalization and Cross-Site Activities).

The fluxes of nutrients from the landscape into streams and then into lakes can clearly alter the function and structure of lake ecosystems. The effects of excessive nutrient addition have been studied in many temperate lakes (Schindler 1977). However, eutrophication of arctic lakes has been studied in only a few places (Persson et al. 1975). In the Toolik Lake region, eutrophication has been studied in limnocorrals (O'Brien et al. 1992), in a divided lake, and a whole lake. The responses of these systems were quite different. The limnocorrals and the whole lake responded with a dramatic increase in phytoplankton and the lake even developed bluegreen algae blooms. However, the divided lake developed less than half the phytoplankton biomass expected. Furthermore, until the fifth year of the experiment there was absolutely no carryover effect from one year to the next. The reason for this anomaly is the very high nutrient sorbing capacity of some arctic lake sediments (Sugai and Kipphut 1992). Hence the need to understand the role of sediment chemistry and surface to volume phenomena in eutrophication in arctic lakes.

Biota, especially predators, can dramatically change the prey structure of lake communities (Brooks and Dodson 1965, Paine 1966). In the Toolik region this is true for many lake predators at several different levels in the foodweb. Lake trout regulate the density and size of the snail *Lymnea elodes* (Merrick et al. 1991) as well as the abundance and habitat distribution of the slimy sculpin ([Fig. 17](#)) (McDonald and Hershey

1992). The slimy sculpin, in its turn, can regulate the density and species composition of the chironomid community (Hanson et al. 1992, Hershey 1985). In many arctic ponds the predaceous copepod *Heterocope septentrionalis* can eliminate small-bodied zooplankton species and structure the community (O'Brien and Luecke 1988). Even in the microbial food web predation is important. Heterotrophic nanoflagellates have been shown to be able to control the densities of lake bacteria populations (Hobbie and Helfrich 1988) and probably structure the community as well.

New Experiments. We propose several new experiments involving fluxes of nutrients and manipulation of biota to better understand the role of these factors in controlling the function and structure of arctic lakes. We plan to add low levels of nitrogen and phosphorus (3X the nutrient loading of Toolik Lake) to two lakes (S-6 and S-7). These two lakes are within 500 m of Toolik Lake with Lake S-6 fairly deep ($z_{\max} = 7.8\text{m}$) and receiving outflow from the much shallower lake S-7 ($z_{\max} = 2.5\text{m}$). Each lake will receive the same aerial nutrient loading but the shallower lake is predicted to retain most of the nutrient added due to a larger ratio of sediment area to lake volume. We plan to sample these lakes with our full complement of measurements weekly from ice-out to mid August. Fish and benthic measurements typically will be taken much less frequently (www.mbl.edu/html/ECOSYSTEMS/Iterhtml/data_doc/lakes/protocols.html).

We also propose to introduce a series of different predators to lakes that lack them to further refine our understanding of the role of predation in structuring arctic lake communities. Little is known about the interactions of arctic char and lake trout and about why they rarely coexist even though their geographic ranges overlap (Fraser and Power 1989). Thus we propose to study Campsite Lake, where the two species coexist, and to introduce adult lake trout into a lake containing arctic char and to introduce adult char into a lake containing lake trout. We also propose to add arctic char to a lake containing arctic grayling and sculpin to see if char have similar impacts to lake trout in such a situation. These lakes will be sampled with the full lakes sampling array once a year.

Lake surveys of slimy sculpin revealed that when they are the only fish present they behave quite differently than when grayling are also present. In lakes without grayling the sculpin are conspicuous on rocks; we hypothesize that in the absence of fish predation they become abundant, deplete their food supply, and shift to dependence on plankton (Hershey 1992). We propose to test this hypothesis by introducing sculpin into a fishless lake and following the density of their benthic prey, chironomids, and the behavior of the sculpin.

Heterocope septentrionalis is known to be a voracious predator on small-bodied zooplankton (O'Brien and Luecke 1988). However, it never co-occurs with *D. pulex*, a favored prey in feeding experiments. We have recently discovered a group of 32 small tundra ponds, 19 of which contain *D. pulex* as the only crustacean zooplankton. We plan to divide 12 of these ponds into 3 groups of 4 ponds each with all the ponds in a given group similar in size, depth, and chemistry. Within a group of 4 ponds, each will receive a different treatment. *Heterocope* will be added to one, *D. middendorffiana* to a second,

both species to a third and nothing to the fourth. These ponds will be sampled biweekly for the densities of these species. Hydrolab chemistry samples will also be taken.

Surveys. We propose to survey nearby lakes that are in different watersheds of various glacial ages to determine if the age induces different rates of nutrient fluxes from the sediment. We will also take sediment cores from these lakes to determine the concentrations and vertical distribution of iron and manganese. The fluxes and cores will be taken once a year. Flux rates will also be taken from two lakes still being fertilized as well as from two previously fertilized lakes. We will also undertake surveys to identify lakes that have lake trout, char or both species. It is important to identify what are the geomorphic characteristics that allow the colonization of these species. Especially interesting are those lakes where both species coexist. These lakes will be sampled with our full suite of lake measurements. Once identified as a lake trout or char lake, such a lake will be sampled annually.

We will undertake a very wide ranging north-south survey (see Alaska Transect, Regionalization and Cross-Site Activities) to determine the effects of different lake temperature regimes. Our modeling of arctic lakes and the bioenergetics of lake trout indicate that changes in the thermal structure of lakes may have important repercussions for lake trout. Of particular interest is the timing of ice-out and degree of mixing prior to summer thermal stratification as well as the condition of lake trout populations. Thermal structure and duration of mixing will be measured by *in situ* thermal data loggers emplaced in selected lakes the autumn prior to measurement. The lakes will be visited in midsummer to retrieve the data loggers and for a full lake analysis and to collect lake trout using gillnets.

Monitoring. We plan to continue monitoring lakes with past or ongoing experiments as well as Toolik Lake, our reference lake (see [Table 2](#)). We sample Toolik Lake (see protocol on web) and measure primary productivity every 10 days, commencing at ice-out and continuing throughout the summer. A similar schedule is kept for two lakes that were fertilized. However, the nine lakes in which fish were added or removed are sampled with the standard lake protocol twice a summer. A previously fertilized lake, N-1, will continue to be sampled for the density and conditions of the lake trout. We collect the fish by angling, then tag and release them.

Modeling. Ecosystem modeling has been shown to be an effective means of increasing our understanding of lake ecosystems (Patterson and Hamblin 1988, Riley and Stefan 1988, Cottingham and Carpenter 1994, and Christopher and G. A. Lawrence 1995). We have three major modeling efforts underway. The Arctic Lake Model (ALM) simulates both the physics and biology of arctic lakes. The physical portion of the model has daily weather data as the only input and uses an eddy diffusion model similar to that of Henderson-Sellers (1984,1986). For winter, the model uses an approach similar to Gu and Stephan (1990) and includes heat storage in the sediment. From this ALM can produce the annual thermal cycle of a lake ([Fig. 18](#)) as well as the annual oxygen depletion cycle during both summer and winter. The biological portion of the model uses nutrient loading and sunlight intensity as input. From this it can produce summer

phytoplankton production and zooplankton biomass by integrating rate equations for nutrients, algae, and zooplankton, for example (Pascual 1994). The remaining phytoplankton is then input to induce summer and winter oxygen depletion. We have used the model to simulate the effect of increased nutrient loading and global change on arctic lakes of differing depths ([Fig. 19](#)). The depths where lake trout can thrive are indeed limited; climate warming of a few degrees will greatly reduce the habitat for these fish.

We have also developed a GIS based model to predict the distribution of lake trout in arctic lakes. The model takes into account the gradient of the outflow of a lake, the presence of lake trout in the drainage, lake size, and depth. The model successfully predicted lake trout distribution in a wide area around Toolik Lake with 86% accuracy. We have published bioenergetics models for lake trout (McDonald et al. 1996) and slimy sculpin (Galarowitz 1994). We have sufficient information on grayling, arctic char, round whitefish, and burbot to begin parameterization of bioenergetic models for these species. Our model of adult lake trout accurately predicted the growth response of lake trout in our fertilized lake (N-1). In the future we plan to integrate these models such that we can model on a much wider scale.

LAND-WATER RESEARCH

Introduction. The arctic ecological system includes the interactions among land, freshwaters, and the atmosphere. These interactions are illustrated in a conceptual model in [Fig. 20a](#). The dominant form of interaction between ecosystems is the flux of materials and the flux of energy through climate forcing; for example, C moves from land to water and from water to the atmosphere, while the land and atmosphere exchange C in both directions.

Although we have made several advances in understanding the role of land-water-atmosphere interactions in the Arctic, there are several missing keys to our ability to make rigorous predictions of how arctic system functioning is controlled. These keys are shown in [Fig. 20b](#), and are highlighted for the controls on C exchanges. For example, it appears that the land-atmosphere connection is governed by soil moisture, landscape age and geological substrate, and vegetation. Differences in parent material and soil age result in landscapes with varying soil pH and vegetation composition -- here we refer to the three dominant types of landscapes found throughout the Arctic as acidic, nonacidic, and shrub tundra, the last of which occurs in warmer areas with deeper thaw (Brubaker et al. 1995); eventually the shrub tundra grades into discontinuous permafrost and trees. The acidic and nonacidic landscapes appear to have very different energy and carbon fluxes (McFadden and Chapin submitted), and we know little about the shrub tundra. The land-water connection appears to be governed by belowground processes such as decomposition, carbon quality, and soil water movement (see Kling 1995). Finally, the water-atmosphere connection is driven by the spatial extent of water, carbon loading from land, and by the meteorological forcings of precipitation, net radiation, and wind. Although this conceptual model is somewhat generalized, it does summarize our current

knowledge of the key processes involved in controlling the major interactions between terrestrial, aquatic, and atmospheric systems in the Arctic.

We study these interactions between systems to better understand ecosystem structure and function. [Fig. 21](#) organizes the relationship between system interactions, ecosystem structure and function, and the key processes and measurements that we focus on in our land-water research. We have, however, only begun to incorporate these concepts and measurements into mathematical models; these models are necessary for extrapolations and predictions of how the arctic system operates and how it will respond to change. Several critical experiments and measurements are needed to provide new information about the linkages between systems and to test our understanding as represented in the models.

What controls the export of C and nutrients from land to aquatic systems?

Background. The general topic of land-water linkages, and specifically the movement of C and nutrients from arctic terrestrial ecosystems to the oceans, is of critical importance to understanding how the Arctic system functions. Although the amounts, forms, and timing of terrestrial exports have been studied extensively, we understand little about the specific plant and soil origins of these materials or the controls on their production and delivery. In temperate and tropical regions, material export from land to water is primarily a function of water flow within specific basins (Swank and Crossley 1988, Lewis and Saunders 1989), and of landscape heterogeneity, such as geologic setting and vegetation type, among different basins. Secondary controls are a function of disturbance (clear-cutting) and biological transformations of organic matter and nutrients (Likens and Bormann 1974, Likens et al. 1977). In the Arctic, there are only a few studies describing the export of materials (Peterson et al. 1986, 1992, Everett et al. 1989, Marion and Everett 1989, Cornwell 1992).

As water moves across a landscape its chemistry is modified by vegetation and soil processes. Some of the most complete research on the role of vegetation in modifying inorganic nutrients in soil waters was done in the Arctic at Imnavait Creek (Marion and Everett 1989) and at the Sagavanirktok River near Toolik (Shaver et al. 1990, Giblin et al. 1991). This latter work studied inorganic N and P dynamics in a toposequence of tundra soils, and showed that different vegetation types and locations differ strongly in their soil water chemistry. In addition to the inorganic nutrients, what little information exists for temperate systems on dissolved organic nutrients (DON, DOP, DOC) in soil waters (e.g., Sollins and McCorison 1981, McDowell and Likens 1988, Binkley et al. 1992) suggests that vegetation type and soil composition control the concentrations. In the Arctic, even though DOM dominates the surface-water budgets of C, N, and P (Whalen and Cornwell 1985, Peterson et al. 1986), we know of no published studies on the production, dynamics, or transfers of soil water DOC and only two references to DON (Shaver et al. 1990, Kielland and Chapin 1992).

Finally, the role of landscape heterogeneity in material export includes the local effects of vegetation and stream size, and the regional effects of landscape age, geology, and soil

composition. As mentioned previously, these factors contribute to forming nonacidic and acidic landscapes, each of which is widespread in the Arctic, and there are clear differences in the chemistry of water draining these two surfaces (Kling et al. 1992).

Previous Research. We found that the amount of C that is exported from land and released to the atmosphere directly from surface waters, or transported to the Arctic Ocean in rivers, is in the range of the net ecosystem productivity (NEP) of the Kuparuk basin. This substantial flux of C from land to water was noted several years ago (Kling et al. 1991), and in our LTER research since then we have learned that this flux is characteristic of other parts of the Arctic and of tropical and temperate systems as well (Kling 1997; Cole et al. 1994). We have also quantified this flux at the scale of the Kuparuk drainage (9200 km²). For the Kuparuk, about 3.7 g C are lost to surface waters per m² of basin each year ([Table 3](#); Kling et al. 1996). Of that C lost, evasion of CO₂ directly to the atmosphere accounts for 32% of the total ([Fig. 22](#)). The evasion of CH₄ from lakes and rivers is small when compared to the total C terms ([Table 3](#)), but is large when compared to the terrestrial fluxes of CH₄ (see Reeburgh and Whalen 1992; Zimov et al. in press; Reeburgh et al. submitted).

In addition to this export of C, we have measured nutrient export in the Kuparuk basin. [Figure 23](#) shows that NH₄⁺ and NO₃⁻ concentrations increase strongly just as soil waters begin to flush into the river during the initial stages of a storm event, highlighting the influence of the soil on material export. We now have an operating process-model to predict water flow and to predict soil conditions such as temperature in these arctic basins ([Fig. 24a and 24b](#)).

Although we now know that the aquatic fluxes of C and nutrients are important, and we have measured some of them in one basin, we still know very little about the factors that control the production and loss at the source of these materials in the soil. A recent experiment done in conjunction with another NSF-funded project at Toolik Lake has measured the rates of production in soil waters of DOC, DIC, CO₂, and CH₄ using a ¹⁴C labeling approach ([Fig. 25](#)).

Given our current knowledge it is apparent that water flow, vegetation and soil uptake and release, and landscape heterogeneity are likely to control the exports of materials to surface waters. In order to increase our understanding of these controls our proposed research is focused on three tasks: (1) measuring soil water C and nutrient concentrations and production in the experimental treatment plots described above; (2) performing water addition experiments to test the effects of soil moisture and water flow; and (3) developing a simulation model to account for the movement of C and nutrients into the soil solution and their transport to surface waters. The information gained will strengthen our process-level understanding of carbon cycling and improve the models we are using to apply this understanding to the pan-arctic scale.

Approach of Proposed Research:

(1) Measurements in experimental plots: To determine the effects of vegetation on material inputs to the soil solution, we will measure the concentrations and seasonal dynamics of materials in soil waters of our LTER experimental treatments near Toolik (described in Terrestrial section). We have been measuring nutrient concentrations in an acidic watershed which contains a primary stream adjacent to our plots (Kling 1995), and we will establish a similar measurement program in an area of non-acidic tundra close to Toolik Lake. These measures will include inorganic nutrients, dissolved gases, and dissolved organic matter (DOC, DON, DOP). Standard sampling will occur every two weeks; there will be extra samples collected during specific rainfall events or climatic extremes. With these measurements we will be able to compare and relate the soil water chemistry to the influence of landscape acidity, vegetation dominance, fertilization, liming, and warming effects. With this design, we will also be able to relate belowground processes to the aboveground responses of vegetation to the experimental treatments. Our estimates of rates of C production will be aided by the ongoing NSF project of Nadelhoffer, Kling, et al. that is designed to follow aboveground ^{14}C additions into belowground pools.

(2) Water addition experiment: To determine the effects of soil moisture and water flow on the production and loss of C and nutrients we will add water to replicate 5x20 m plots in our acidic and nonacidic tundra sites near Toolik. We will add water at ~200% of the normal precipitation during the summer. The same suite of soil water measurements described above will be made every two weeks and during selected climate extremes. The vegetation in the water addition experiment will be harvested in year 4 as described in Question 2. As an additional approach to understanding the factorial effects of changing soil moisture with our other treatments (fertilization, warming, etc.), we will add water at low, medium, and high levels (high levels will simulate saturated soil conditions following large rain events) to soil cores and soil-plant microcosms taken from the treatment plots. These experiments will be done in years 3 and 4 of the project to allow for the maximum treatment effects. Concentrations of nutrients, DOM, and dissolved gases in the microcosms will be measured as the soils are "flushed" at different rates. Once concentrations of dissolved materials are at background or steady levels, the flushing will be stopped and we will monitor the rates of production and buildup of C and nutrients in the soil waters.

(3) Modeling: In order to improve our understanding of soil water processes, we will develop models to account for the production of nutrients, DOC, and CO_2 in the soil solution and the subsequent movement of these materials to surface waters. The first model will simulate CO_2 concentrations in the soil atmosphere and in soil water as a function of four fluxes: (1) the supply of CO_2 to the soil through soil and root respiration will be supplied from GEM; (2) the export of CO_2 from the soil to the atmosphere will be proportional to the concentration difference between the soil and atmosphere; (3) a steady-state will be assumed between CO_2 in the soil atmosphere and in the soil water; and (4) the losses of CO_2 in ground water will be proportional to the concentration of CO_2 in the ground water and the rate of groundwater discharge. Other than the water balance parameters, this model will require the estimation of only one parameter, the exchange parameter for the flux of CO_2 from the soil to the atmosphere. The second and

third models will operate similarly to the first model. The models will estimate the supply of DOC and nutrients using terms already present in GEM; dissolved nutrients and DOC will be related to the extractive pools represented in GEM. The experimental results will allow the necessary calibration of these submodels within GEM's decomposition routine. Because we have information at the basin scale on the amounts of C and nutrients that are exported from land, we can constrain the soil C and nutrient production and loss estimates of the model.

As part of our modeling, our need for quality meteorological input to GEM and TEM, and our focus on C flux from surface waters, we will work with the funded Lynch-Chapin project (NSF-ARCSS) and the funded project of MacIntyre (NSF-DEB) to better understand the surface energy budgets of lakes. This is essential because from 20-70% of the coastal plain is water; thus it is necessary to know what controls the evasion of CO₂ and evaporation of water at the air-water interface. With this information we can improve our quantification of the aquatic portion of the C budget, which is critical in testing our representation of the processes of C loss in GEM. Shallow lakes on the coastal plain have never been characterized for water and CO₂ exchanges. We will measure mechanisms of CO₂ and energy exchange with Chapin and MacIntyre at Toolik Lake and at Lake Colleen on the coastal plain to help determine why evaporation and trace-gas fluxes cannot be predicted by conventional boundary layer models.

Regionalization And Cross-Site Activities

Table 4 lists the on-going and planned studies involving the P.I.'s of the Arctic LTER project. One large study, the Arctic Natural Sciences (NSF Office of Polar Programs) project, deserves special note because it is closely linked to the LTER project and has similar aquatic goals. It has been renewed a number of times on a 3-year cycle. This project provides subcontract and R.A. funds while the LTER provides administrative funds and the R.A.'s who carry out much of the monitoring and maintain the large experiments.

Another project, the Regional GIS and the Toolik Atlas being constructed by Donald Walker of the University of Colorado, is funded in part by a subcontract from the Arctic LTER. For this contribution, Walker provides the data files for the hierarchical GIS for the Toolik, Kuparuk, Northern Alaska, and Arctic regions.

Four projects, Abisko-Toolik, LINX, LIDET, and Diversity, are continuing NSF projects that use data from Toolik in a cross-site comparison. The Abisko site is at the same latitude as Toolik in northern Sweden; similar terrestrial measurements and experiments are being carried out at both sites with U.S., Swedish, and Danish scientists. LIDET is a major LTER comparative study of decomposition while Diversity involves the use of LTER data sets to investigate links between diversity and ecosystem functions.

The five projects funded through the NSF Arctic System Sciences (ARCSS) all rely heavily on the fundamental information on ecosystem structure, function, and processes developed over the years at the Toolik sites. For example, the GEM modeling is

calibrated with the experimental data on the tussock and wet sedge tundra sites at Toolik. It has been applied at a number of sites in the 8,000 km² Kuparuk River basin as well as forward and backwards 200 years. The Giblin/Stieglitz project utilizes a landscape-scale hydrology model coupled with a respiration and nutrient cycling model to study the land-water transfer of water and material in different habitats.

The LTER Alaska Transect project is a joint venture of the Arctic and Bonanza Creek LTER projects. The overall goal is to forge links between these two projects through a joint effort to collect spatially-distributed data along a transect cutting across the entire state. Financial resources are scarce and much planning remains to be done in order to obtain the best possible information when only a brief sampling is possible. Because both aquatic and terrestrial measurements will be made, the sites will be chosen so that both types of samples are collected in the same region of the same watershed. Maximum use will be made of remote sensing (AVHRR, SAR, LANDSAT) and continuous recorders (weather stations, stream flow and temperature). The direct gain to the Arctic LTER project will be information on response of species and processes to different conditions. For example, the ecosystems arrayed along the south side of the Brooks Range experience summer temperatures that are similar to those predicted for the Arctic within the next century. We will use the data to test model predictions and expand our understanding of the spatial variability of northern Alaska.

Synthesizing Research: Linkages Within The Arctic LTER; Contributions To Broader Ecological Issues

Synthesizing the Arctic LTER. In this proposal, the Arctic LTER project has been presented in four parts, terrestrial, streams, lakes, and land-water interactions. The reality is a closely integrated project that encompasses the whole system at Toolik Lake. What are the various ways we achieve integration?

- Overall conceptual framework. Our work on the four parts of the project fits within a single conceptual framework which outlines the controls of ecosystem structure and function (Figs. 7, 9, 12, 15, 21). The terrestrial, stream, and lake ecosystems all respond to changes in the physical setting, climate, biota, and are closely linked through the fluxes of carbon, water, energy, and nutrients (see [Fig. 20](#), the Physical-Biogeochemical Arctic System). For example, nutrients from land control primary productivity of streams and lakes while the evapotranspiration and energy exchange in the terrestrial system controls the soil moisture of the tundra and also the amount of water moving into streams.
- Scientific breadth of individuals. The scientists on this LTER project have ecological understanding of several of the subsystems at Toolik Lake; in fact they often work on more than one subsystem. For example, Anne Hershey works on both stream and lake insect ecology while George Kling works on lake and stream nitrogen cycling and on water and material transport from land to water and water to the atmosphere.
- Modeling. The hydrology/soil processes/nutrient flux model being developed by Kling, Stieglitz, and Giblin, specifically link the different parts of the ecosystem.

Another model, the geomorphic-trophic model of potential fish distribution, links the physical setting and stream characteristics to the distribution of lake trout and other top predators. Our lake model includes the input of phosphorus from land and streams as a key factor in lake primary and secondary production.

- Synthesis Book. We are developing a book, one of the series of LTER Synthesis volumes, that will describe these three different ecosystems and the various processes that control their structure and function. We have already published general descriptions of these ecosystems (Shaver et al. 1996, Hershey et al. 1997, O'Brien et al. 1997) and in this book we will focus on integrating the experiments on controls of ecosystem structure and function. We will also include a section on arctic ecosystems in a global ecological perspective. Writing assignments are to be made in the spring of 1998 with publication two years later.

Contributions to Broader Ecological Issues

1). One challenge that confronts ecologists is the need to integrate processes at the population, community and ecosystem levels. Such an understanding would represent not only a theoretical advance, but allow managers to make decisions on questions as diverse as enhancing a fishery (population), restoring biodiversity (community) or regulating nutrient fluxes (ecosystem). Our work on the Arctic LTER is an integrated research program that addresses specific processes - population based and ecosystem based - on different spatial scales. For example, in the streams program the combination of the geomorphic trophic analysis and the ^{15}N tracer additions will help to determine if animal production varies with stream order and position in the watershed in a manner similar to N retention and recycling. In the terrestrial program one goal is to describe how biotic diversity and community composition in the soil is determined by the geomorphology, climate, and fluxes.

2). Understanding how ecosystems respond to and if, and at what rate, they return to a state similar to pristine conditions after a major disturbance is a critical question in ecology. Our experimental manipulations of lakes, streams and rivers are designed to help predict the long-term response to perturbation of communities and ecosystem processes. We have discovered in these experiments that the short-term responses of ecosystems do not necessarily predict the final new equilibrium. For example, it took 9 years for shrubs to become dominate in the heated and fertilized greenhouses on acidic tussock tundra. It is also important to understand if disturbances leave long-lasting impacts. These ecological 'legacies' have been defined as the remnants of past biological and physical disturbances (Naiman et al. 1995). To determine if nutrient addition leaves a legacy, we have conducted long-term fertilization experiments on biota and ecosystem processes in lakes and streams. In the lake experiment, we are in the 8th year of monitoring the recovery after 6 years of treatment; in the stream experiment, we are in the 2nd year of recovery after 6 years of treatment.

3). Another major challenge is to understand the role of variability across the landscape in affecting ecosystem structure and function. Placement in the landscape can control community composition, ecosystem processes, and linkages between ecosystems. For

example, the lateral linkages to riparian corridors and inputs from land may be more important in small streams than in large streams (Vannote et al. 1980, Townsend 1996). We are testing these ideas through our P fertilization and ¹⁵N experiments in different sized streams. The geomorphic trophic hypothesis being developed for both lakes and streams will specifically investigate the importance of landscape geomorphology in determining community composition and ecosystem function.

4). The importance of top-down controls remains a central issue in ecology (e.g., the special 1992 feature in *Ecology* 73 No. 3). Most of the research on top-down control in aquatic systems has been carried out in relatively eutrophic lakes or streams with greatly modified community structures (e.g., Allan and Flecker 1993, Carpenter and Kitchell 1988). A full understanding of the top-down controls in relatively pristine systems would enable us to prevent damage or restore degraded systems. We now have new information on top-down controls by lake trout, arctic char, arctic grayling, and sculpin in oligotrophic systems. Moreover, we are beginning to use the data we have from lakes and streams at different levels of eutrophication to address (e.g., Hobbie et al. in press) the question of changes in control with trophic level.

literature cited

Allan,JD, Flecker,AS, (1993) Biodiversity conservation in running waters.
BioScience 43:32-43.

AMAP (1997) Arctic Pollution Issues: A state of the environment report. Arctic Monitoring and Assessment Programme. Oslo.

Bahr,M, Hobbie,JE, Sogin,ML (1996) Bacterial diversity in an arctic lake: a freshwater SAR11 cluster. *Aquat. Microb. Ecol.* 11:271-277.

Batzli,GO (ed) (1980) Patterns of vegetation and herbivory in arctic tundra: results from the Research on Arctic Tundra Environments (RATE) program. *Arctic Alp. Res.* 12 (4)401-518.

Billen,G, Varnier,J, Hanset,P (1994) Modeling phytoplankton development in whole drainage networks: the RIVERSTRAHLER model applied to the Seine River system. *Hydrobiologia* 289:119-137.

Billings,WD (1973) Arctic and alpine vegetations: similarities, differences, and susceptibility to disturbance. *BioScience* 23:697-704.

Billings,WD, Mooney,HA (1968) The ecology of arctic and alpine plants. *Biological Rev.*43:481-530.

Binkley,D, Sollins,P, Bell,R, Sachs,D, Myrold,D (1992) Biogeochemistry of adjacent conifer and alder-conifer stands. *Ecology* 73:2022-2033.

- Bowden, WB, Peterson, BJ, Finlay, JC, Tucker, J (1992) Epilithic chlorophyll a, photosynthesis and respiration in control of a tundra stream. *Hydrobiologia* 240:121-132.
- Bowden, WB, Finlay, JC, Maloney, PE (1994) Long-term effects of PO₄ fertilization on the distribution of bryophytes in an arctic river. *Freshwater. Biol.* 32:454.
- Bret-Harte, MS, Shaver, GR, Zoerner, JP, Johnstone, JF, Wagner, JL, Chavez, AS, Gunkelman, RF, Lippert, SC, Laundre, JA (Submitted) Individual growth and species performance of three arctic shrubs exposed to long-term warming and fertilization in Alaskan tussock tundra. *Ecology*.
- Brooks, JL, Dodson, SL (1965) Predation, body-size and the composition of the plankton. *Science* 150:28-35.
- Brown, J, Miller, PC, Tieszen, LL, Bunnell, FL (eds.) (1980) *An Arctic Ecosystem. The Coastal Tundra at Barrow, Alaska.* Dowden, Hutchinson and Ross, Stroudsburg, PA. 571pgs.
- Brubaker, LB, Anderson, PM, Hu, FS (1995) Arctic tundra biodiversity: A temporal perspective from late-quaternary pollen records. *In* Chapin, FS, Korner, C (eds.), *Arctic and Alpine Biodiversity.* Berlin, Springer-Verlag. p. 295-301.
- Bunn, SE, Hughes, JM (1997) Dispersal and recruitment in streams: evidence from genetic studies. *J. N. Am. Benthol. Soc.* 16(2):338-346.
- Carpenter, SR, Kitchell, JF (1988) Consumer control of lake productivity. *Bioscience* 38:764-769.
- Chapin, FS III (1983) Direct and indirect effects of temperature on arctic plants. *Polar Biology* 2:47-52.
- Chapin, FS III, Shaver, GR, Giblin, AE, Nadelhoffer, KJ, Laundre, JA (1995) Responses of arctic tundra to experimental and observed changes in climate. *Ecology* 76(3):694-711.
- Chapin, FS, III, Shaver, GR (1996) Physiological and growth responses of arctic plants to a field experiment simulating climatic change. *Ecology* 77: 822-840.
- Christopher, KR, Lawrence, GA (1995) Observations and numerical simulation of a shallow ice-covered midlatitude lake. *Limnol. Oceanogr.* 40:374-385.
- Cole, JJ, Caraco, N, Kling, GW, Kratz, T (1994) Carbon dioxide supersaturation in the surface waters of lakes. *Science* 265:1568-1570.

- Cornwell, JC (1992) Cation export from an Alaskan arctic watershed. *Hydrobiologia* 240:15-22.
- Cornwell, JC, Kipphut, GW (1992) Biogeochemistry of manganese- and iron-rich sediments in Toolik Lake, Alaska. *Hydrobiologia* 240:45-59.
- Cottengham, KL, Carpenter, SR (1994) Predictive indices of ecosystem resilience in models of North Temperate Lakes. *Ecology* 75:2127-2138.
- Craig, PC, McCart, PJ (1975) Classification of stream types in the Beaufort Sea drainages between Prudhoe Bay Alaska and the MacKenzie Delta, NWT. *Arctic Alp. Res.* 7:183-198.
- Cuker, BE, McDonald, ME, Mozley, SC (1992) Influences of slimy sculpin (*Cottus cognatus*) predation on the rocky littoral invertebrate community of an arctic lake. *Hydrobiologia* 240:83-90.
- De Ruiter, PC, Neutel, AM (1995) Energetics, patterns of interaction strengths, and stability in real ecosystems. *Science* 269:1257-1260.
- Deegan, LA, Peterson, BJ (1992) Whole river fertilization stimulates fish production in an arctic tundra river. *Can. J. Fish. Aquat. Sci.* 49:1890-1901.
- Deegan, LA, Peterson, BJ, Golden, H, MacIvor, CC, Miller, MC (1997) Effects of fish density and river fertilization on algal standing stocks, invertebrate communities and fish production in an arctic river. *Can. J. Fish. Aquat. Sci.* 54(2):269-283.
- Deegan, LA, Golden, H, Harvey, C, Peterson, BJ (Submitted) Influence of summer stream flow and temperature on the growth of adult and young-of-the-year Arctic grayling. *Trans. Amer. Fish. Soc.*
- Edwardson, KJ (1997) Characterization of hyporheic influences on the hydrology and geochemistry in contrasting arctic streams. MS Thesis, University of New Hampshire, Durham, NH.
- Eisner, WR, Colinvaux, PA (1992) Late quaternary pollen records from Oil Lake and Feniak Lake, Alaska, USA. *Arctic Alp. Res.* 24:56-63.
- Everett, KR, Marion, GM, Kane, DL (1989) Seasonal geochemistry of an arctic tundra drainage basin. *Holarctic Ecology* 12:279-289.
- Ford, J, Landers, D, Kugler, D, Lasorsa, B, Allen-Gil, S, Crecelius, E, Martinson, J (1995) Inorganic contaminants in Arctic Alaskan ecosystems: long-range atmospheric transport or local point sources? *In* The Science of the Total Environment, Nriagu, JO (ed.), Elsevier, Amsterdam. Vol 160,161 p.323-335.

- Fraser,NC, Power,G (1989) Influences of lake trout on lake-resident Arctic char in northern Quebec, Canada. *Trans. Am. Fish. Soc.* 118:36-45.
- Frissell,CA, Liss,WA, Warren,CE, Hurley,DM (1986) A heirarchical framework for stream habitat classification: viewing streams in the watershed context. *Environ. Management* 10: 199-214.
- Galarowicz,TL (1994) Effects of slimy sculpin (*Cottus cognatus*) removal on sculpin and chironomid (Diptera: Chironomidae) populations in an arctic lake. MS Thesis, University of Minnesota, Duluth, MN.
- Gibeau,GG, Miller,MC (1989) A micro-bioassay for epilithon using nutrient diffusing artificial substrate. *J. Freshwater Ecol.* 5:171-176.
- Giblin,AE, Likens,GE, White,D, Howarth,RW (1990) Sulfur storage and alkalinity generation in New England lake sediments. *Limnol. Oceanogr.* 35:852-869.
- Giblin,AE, Nadelhoffer,KJ, Shaver,GR, Laundre,JA, McKerrow,AJ (1991) Biogeochemical diversity along a riverside toposequence in Arctic Alaska. *Ecol. Monogr.* 61:415-435.
- Gold,WG, Bliss,LC (1995) Water limitations and plant community development in a polar desert. *Ecology* 76:1558-1568.
- Golden,H, Deegan,LA (In press) Top-down control by young-of-the-year grayling in a tundra stream. *Freshwat. Biol.*
- Gough,L, Gross,KL, Collins,SL, Osenberg,CW (Submitted) Fertilization effects on plant species diversity in herbaceous plant communities. *Ecology, Special Feature section on diversity/productivity relationships.*
- Gough,L, Shaver,GR (Submitted) Diversity/productivity relationships in arctic vegetation. *Ecology, Special Feature section on diversity/productivity relationships.*
- Goyke,AP, Hershey,AE (1992) Effects of fish predation on larval chironomid (*Diptera; Chironimidae*) communities in arctic ecosystems. *Hydrobiologia* 240 (Dev. Hydrobiol. 78) 203-211.
- Gu,R, Stefan,HG (1990) Year-round temperature simulation of cold climate lakes. *Cold Regions Science and Technology* 18:147-160
- Hall,RO Jr, Peterson,BJ, Meyer,JL (In press) Testing a nitrogen cycling model of a forest stream using a ¹⁵N tracer addition. *Ecosystems.*

Hanson,KL, Hershey,AE, McDonald,ME (1992) A comparison of slimy sculpin (*Cottus cognatus*) populations in arctic lakes with and without piscivorous predators. *Hydrobiologia* 240:189-201.

Harvey,CJ, Peterson,BJ, Bowden,WB, Hershey,AE, Miller,MC, Deegan,LA, Finlay,JC (In press) Biological responses of Oksrukuyik Creek, a tundra stream, to fertilization. *J. N. Am. Benthol. Soc.*

Hawkins,CP, Kershner,JL, Bisson,PA, Bryant,MD, Decker,LM, Gregory,SV, McCullough,DA, Overton,CK, Reeves,GH, Steedman,RJ, Young,KM (1993) A hierarchical approach to classifying streams. *Fisheries*: 18: 3 -10.

Henderson-Sellers,B (1984) *Engineering Limnology*. Pitman, Boston.

Henderson-Sellers,B (1986) Calculating the surface energy balance for lake and reservoir modeling: A review. *Reviews of Geophysics* 24:625-649.

Hershey,AE (1985) Effects of predatory sculpin on the chironomid communities of an arctic lake. *Ecology* 66:1131-1138.

Hershey,AE (1990) Snail populations in arctic lakes: Competition mediated by predation? *Oecologia* 82:266-32.

Hershey,AE (1992) Effects of experimental fertilization on the benthic macroinvertebrate community of an arctic lake. *J. N. Am. Benthol. Soc.* 11:204-217.

Hershey,AE, Hiltner,AL (1988) Effect of a caddisfly on black fly density: interspecific interactions limit black flies in an arctic river. *Journal of the North American Benthological Society* 7:188-196.

Hershey,AE, Hiltner,AL, Hullar,MAJ, Miller,MC, Vestal,RJ, Lock,MA, Rundle,S, Peterson,BJ (1988) Nutrient influence on a stream grazer: *Orthocladus* microcommunities respond to nutrient input. *Ecology* 69(5)1383-1392.

Hershey,AE, Pastor,J, Peterson,BJ, Kling,GW (1993) Stable isotopes resolve the drift paradox for *Baetis* mayflies in an arctic river. *Ecology* 74:2315-2325.

Hershey,AE, Merritt,RW, Miller,MC (1995) Insect diversity, life history, and trophic dynamics in arctic streams, with particular emphasis on blackflies (Diptera: Simuliidae). *In* Chapin,FS,III, Koerner,K (eds.) *Arctic and Alpine Biodiversity*. Ecological Studies Vol. 113. Springer-Verlag, Berlin. p. 283-295.

Hershey,AE, Bowden,WB, Deegan,LA, Hobbie,JE, Peterson,BJ, Kipphut,GW, Kling,GW, Lock,MA, Miller,MC, Vestal,JR (1997) *The Kuparuk River: A long-*

term study of biological and chemical processes in an arctic river. *In* Milner,A, Oswald,MW (eds.), *Freshwaters of Alaska*.Springer-Verlag. p.107-129.

Hershey,AE, Gettel,G, McDonald,ME, Miller,MC, Moors,H, O'Brien,WJ, Pastor,J, Richards,C, Schyldt,JA (Submitted) A geomorphic-trophic model for landscape control of trophic structure in arctic lakes. *Bioscience*.

Hobbie,JE, ed. (1980) *Limnology of Tundra Ponds: Barrow, Alaska*. Dowden, Hutchinson and Ross, Stroudsburg, Pennsylvania. 514 pages.

Hobbie, JE (1997) History of limnology in Alaska. *In* *Freshwaters of Alaska*, Milner,A, Oswald,MW (eds.), Springer-Verlag, NY. P.45-60.

Hobbie,JE, Helfrich,JVK (1988) The effect of grazing by microprotozoans on production of bacteria. *Arch. Hydrobiol.* 31:281-288.

Hobbie,JE, Bahr,M, Rublee,P (In press) Controls on microbial food webs in oligotrophic arctic lakes. *Arch. Hydrobiol. Beih.*

Imhof,JG, Fitzgibbon,J, Annable,WK (1996) A heirarchical evaluation system for characterizing watersheds ecosystems for fish habitat. *C. J. Fish. Aquat. Sciences* 53(supple. 1) 312-326.

Jefferies,RL, Klein,DR, Shaver,GR (1994) Herbivores and northern plant communities: reciprocal influences and responses. *Oikos* 71:193-206.

Johnson,L (1976) Ecology of arctic populations of lake trout *Salvelinus namaycush*, lake white fish, *Coregonus clupeaformis*, arctic char, *S. alpinus*, and associated species in unexploited lakes of the Canadian Northwest Territories. *J. Fish. Res. Board Can.* 33:2459-2488.

Johnson,LC, Shaver.GS, Giblin,AE, Nadelhoffer,KJ, Rastetter,EB, Laundre,JA, Murray,GL (1996) Effects of drainage and temperature on carbon balance of tussock tundra microcosms. *Oecologia* 108:737-748.

Johnson,L, Shaver,GR, Cades,D, Rastetter,E, Nadelhoffer,KJ, Giblin,A, Laundre,J, Stanley,A (Submitted) Carbon-nutrient interactions control CO₂ exchange in Alaskan wet sedge ecosystems.

Jonasson,S, Shaver,GR (In press) Within-stand nutrient cycling in arctic and boreal herbaceous and forested wetlands. *In* Whigham,D, Feller,I (eds.), *SpecialFeatures section on Wetland Ecosystems*. *Ecology*.

Kerr,RA (1998) The hottest year, by a hair. *Science* 279:315-316.

Kielland,K, Chapin,FS III (1992) Nutrient absorption and accumulation in arctic plants. *In* Chapin,FS III, Jeffries,RL, Reynolds,JF, Shaver,GR, Svoboda,J (eds.), *Arctic Ecosystems in a Changing Climate*. Academic Press, San Diego. p.321-336.

Kling,GW (1994) Ecosystem-scale experiments in freshwaters: the use of stable isotopes, *In* Baker,LA (ed.), *Environmental Chemistry of Lakes and Reservoirs*. Advances in Chemistry Series 237. American Chemical Society, Washington D.C. p.91-120.

Kling,GW (1995) Land-water linkages: the influence of terrestrial diversity on aquatic systems. *In* Chapin,FS, Korner,C (eds.), *The Role of Biodiversity in Arctic and Alpine Tundra Ecosystems*, Springer-Verlag, Berlin. p.297-310.

Kling,GW (1997) Patterns and causes of CO₂ saturation in surface waters at landscape and continental scales: results of a multi-investigator workshop. American Society of Limnology and Oceanography, National Meeting, 10-14 February 1997, Santa Fe, NM. p210.

Kling,GW, Kipphut,GW, Miller,MC (1991) Arctic lakes and streams as gas conduits to the atmosphere: implications for tundra carbon budgets. *Science* 251:298-301.

Kling,GW, Kipphut,GW, Miller,MC (1992) The flux of CO₂ and CH₄ from lakes and rivers in arctic Alaska. *Hydrobiologia* 240:23-36.

Kling,GW, Kipphut,G, Bowden,WB, Edwardson,K (1996) Carbon balance in arctic regions: the role of lakes and streams. American Geophysical Union, National Meeting, 15-19 December, San Francisco. p. F257.

LaPerriere,JD (1981) Vernal overturn and stratification of a deep lake in the high subarctic under ice. *Verh. Internat. Verein. Limnol.* 21:288-292.

Lewis,WM Jr, Saunders,JF III (1989) Concentration and transport of dissolved and suspended substances in the Orinoco River. *Biogeochemistry* 7:203-240.

Likens,G, Bormann,FH (1974) Linkages between terrestrial and aquatic ecosystems. *Bioscience* 24:447-456.

Likens,G, Bormann,FH, Pierce,R, Eaton,J, Johnson,MN (1977) *Biogeochemistry of a Forested Ecosystem*. Springer-Verlag, NY.

Lock,MA, Ford,TE, Fieberg,DM, Miller,MC, Hullar,M, Vestal,JR, Peterson,BJ (1989) A biogeochemical survey of rivers and streams in the mountains and foothills province of arctic Alaska. *Hydrobiologia* 115: 499-521.

- Mackay,RJ (1992) Colonization by lotic macroinvertebrates: a review of processes and patterns. *C. J. Fish. Aq. Sci.* 49:617-628.
- Marion,GM, Everett,KR (1989) The effect of nutrient and water additions on elemental mobility through small tundra watersheds. *Holarct. Ecol.* 12:317-323.
- Maxwell,B (1992) Arctic climate: potential for change under global warming. *In* Chapin,FS III, Jefferies,RC, Reynolds,JF, Shaver,GR, Svoboda,J (eds.), *Arctic Ecosystems in a Changing Climate: An Ecophysiological Perspective*. Academic Press, SanDiego, CA. P.11-34.
- McDonald,ME, Hershey,AE (1992) Shifts in abundance and growth of slimy sculpin in response to changes in the predator population in an arctic lake. *Hydrobiologia* 240:219-224.
- McDonald,ME, Hershey,AE, Miller,MC (1996) Global warming impacts on lake trout in arctic lakes. *Limnol. Oceanogr.* 41:1102-1108.
- McDowell,WH, Likens,GE (1988) Origin, composition, and flux of dissolved organic carbon in the Hubbard Brook Valley. *Ecol. Monogr.* 58:177-195.
- McFadden,JP, Chapin,FS III (Submitted) Surface energy balance differences among Arctic tundra ecosystems. *Journal of Geophysical Research*.
- McKane,RB, Rastetter,EB, Shaver,GR, Nadelhoffer,KJ, Giblin,AE, Laundre,JA, Chapin,FS III (1997a) Reconstruction and analysis of historical changes in carbon storage in arctic tundra. *Ecology* 78:1188-1198.
- McKane,RB, Rastetter,EB, Shaver,GR, Nadelhoffer,KJ, Giblin,AE, Laundre,JA (1997b) Climatic effects on tundra carbon storage inferred from experimental data and a model. *Ecology* 78:1170-1187.
- Melack,JM, Dozier,J, Goldman,CR, Greenland,D, Milner,A, Naiman,RJ (1997) Effects of climate change on inland waters of the Pacific Coastal Mountains and Western Great Basin of North America. *In* Symposium on Regional Assessment of Freshwater Ecosystems and Climate change in North America. C. E. Cushing,CE (ed.), John Wiley & Sons, NY NY. p. 971-992
- Merrick,GW, Hershey,AE, McDonald,ME (1991) Lake trout (*Salvelinus namaycush*) control of snail density and size distribution in an arctic lake. *Can. J. Fish. Aq. Sci.* 48:498-502.
- Michaelson,GJ, Ping,CL, Kling,GW, HobbieJE (Submitted) The character and bioactivity of dissolved organic matter at thaw and in the spring runoff waters of the Arctic Tundra North Slope, Alaska. *Journal of Geophysical Research*.

- Molau,J,Shaver,GR (1997) Controls on seed production and seed germinability in *Eriophorum vaginatum*. *Global Change Biology*, Special issue on ITEX research. 3 suppl.1:146-157.
- Moore,JC, Hunt,HW (1988) Resource compartmentation and the stability of real ecosystems. *Nature* 333:261-263.
- Moore,JC, Walter,DE, Hunt,HW (1989) Habitat compartmentation and environmental correlates of food chain length. *Science* 243:238-239.
- Moore,JC, de Ruiter,PC, Hunt,HW (1993) Influence of productivity on the stability of real and model ecosystems. *Science* 261:906-
- Morin,R, Naiman,RJ. (1990) The relation of stream order to fish community dynamics in boreal forest watersheds. *Hydrobiologia* 38:135-150.
- Nadelhoffer,KJ, Giblin,AE, Shaver,GR, Laundre,JA (1991) Effects of temperate and organic matter quality on C, N, and P mineralization in soils from six arctic ecosystems. *Ecology* 72:242-253.
- Nadelhoffer,KJ, Shaver,GR, Giblin,AE, Johnson,L, McKane,R (1996) ¹⁵N natural abundances and N use by tundra plants. *Oecologia* 107:386-394.
- Naiman,RJ, Magnusen,JJ, McKnight,DM, Stanford,JA (1995) The freshwater imperative: a research agenda. Island Press, Washington, D.C.
- O'Brien,WJ, Buchanan,C, Haney,JF (1979) Arctic zooplankton community structure: exceptions to some general rules. *Arctic* 32:237-247.
- O'Brien,WJ, Evans,BI (1992) Simulation model of the planktivorous feeding of arctic grayling: laboratory and field verification. *Hydrobiologia* 240:235-246.
- O'Brien,WJ, Luecke,C (1988) The coexistence of a predaceous copepod and a daphnid: Weeding and gardening in the arctic. *Verh. Int. Verein. Limnol.* 23:2069-2074.
- O'Brien,WJ, Hershey,A, Hobbie,J, Hullar,MA, Kipphut,GW, Miller,MC, Moller,B, Vestal,JR (1992) Control mechanisms of arctic lake ecosystems: a limnocorral experiment. *Hydrobiologia* 240:143-188.
- O'Brien,WJ, Bahr,M, Hershey,A, Hobbie,J, Kipphut,G, Kling,G, Kling,H, McDonald,M, Miller,M, Rublee,P, Vestal,R (1997) The limnology of Toolik Lake. *In* Milner,A, Oswood,MW (eds.), *Freshwaters of Alaska*. Springer-Verlag, N.Y. p. 61-106.

- Osterkamp,T (1994) Evidence for warming and thawing of discontinuous permafrost in Alaska. *Eos* 75 (44)85.
- Paine,RT (1966) Food web complexity and species diversity. *American Nat.* 100:65-75.
- Paine,RT, Levin,SA (1981) Intertidal landscapes: Disturbance and the dynamics of pattern. *Ecological Monographs* 51:145-178.
- Pascual,M (1994) Periodic response to periodic forcing of the Droop equations for phytoplankton growth. *J. Math. Biol.* 32:743-759.
- Patterson,JC, Hamblin,PF (1988) Thermal simulation of a lake with winter ice cover. *Limnol. Oceanogr.* 33:323-338.
- Persson,G, Holmgren,SK, Jansson,M, Lundgren,A, Nyman,B, Solander,C, Anell,C (1975) Phosphorus and nitrogen and the regulation of lake ecosystems: experimental approaches in subarctic Sweden. *In Proc. Circumpolar Confer. Northern Ecol. N. R. C. Canada* p. III-1-19.
- Peterson,BJ, Hobbie,JE, Corliss,TL, Kriet,K (1983) A continuous-flow periphyton bioassay: tests of nutrient limitation in a tundra stream. *Limnol. Oceanogr.* 28:583-591.
- Peterson,BJ, Hobbie,JE, Hershey,AE, Lock,M, Ford,T, Vestal,JR, McKinley,VL, Hullar,MA, Ventullo,JR, Volk,G (1985) Phosphorus addition transforms a tundra river from heterotrophy to autotrophy. *Science* 229(4720)1383-1386.
- Peterson,BJ, Hobbie,JE, Corliss,TL (1986) Carbon flow in a tundra stream ecosystem. *Can. J. Fish. Aquat. Sci.* 43(6)1259-1270.
- Peterson,BJ, Deegan,L, Helfrich,J, Hobbie,JE, Hullar,M, Moller,B, Ford,TE, Hershey,A, Hiltner,A, Kipphut,G, Lock,MA, Fiebig,DM, McKinley,V, Miller,MC, Vestal,JR, Ventullo,R, Volk,G (1993) Biological responses of a tundra river to fertilization. *Ecology* 74(3)653-672.
- Peterson,BJ, Bahr,M, Kling,GW (1997) A tracer investigation of nitrogen cycling in a pristine tundra river. *Can. J. Fish. Aquat. Sci.* 54(10)2361-2367.
- Peterson,BJ, Wollheim,WJ, Deegan,LA, Bahr,M, Jones,D, Bowden,WB, Hershey,AE, Kling,GW, Miller,MC (Submitted): A coupled field and modeling approach for the study of nitrogen cycling in streams: the Kuparuk River case study. *J. N. Am. Benthol. Soc.*
- Peterson,BJ, Wollheim,WJ, Deegan,LA, Bahr,M, Jones,D, Bowden,WB, Hershey,AE, Kling,GW, Miller,MC (Submitted) A coupled field and modeling

approach for the study of nitrogen cycling in streams: the Kuparuk River case study. *J. N. Am. Benthol. Soc.*

Pickett,STA, White,PS (1985) The ecology of natural disturbance and patch dynamics. Academic Press, Orlando, Fl.

Poff,NL (1997) Landscape filters and species traits: towards mechanistic understanding and prediction in stream ecology. *J. N. Am. Benthol. Soc.* 16(2)391-409.

Rastetter,EB, McKane,RB, Shaver,GR, Nadelhoffer,KJ, Giblin,AE (1997) Analysis of CO₂, temperature, and moisture effects on carbon storage in Alaskan arctic tundra using a general ecosystem model. *In* Oechel,WC, Holten,J (eds.) *Global Change and Arctic Terrestrial Ecosystems*. Springer-Verlag, NY.

Reeburgh,WS, Whalen,SC (1992) High latitude ecosystems as CH₄ sources. *Ecological Bulletin* 42:62-70.

Reeburgh,WS, King,JY, Regli,SK, Kling,GW, Auerbach,NA, Walker,DA (Submitted) A CH₄ emission estimate for the Kuparuk River Basin. *Journal of Geophysical Research*.

Riley,MJ, Stefan,HG (1988) MINLAKE: A dynamic lake water quality simulation model. *Ecological Modeling* 43:155-182.

Rouse,WR, Douglas,M, Hecky,RE, Hershey,A, Kling,GW, Lesack,L, Marsh,P, McDonald,M, Nicholson,B, Roulet,N, Smol,J (1997) Effects of climate change on the fresh waters of arctic and subarctic North America. *Hydrological Processes* 11:873-902.

Rublee, PA, Bettez, N (1995) Change of microplankton community structure in response to fertilization of an arctic lake. *Hydrobiologia* 312:183-190.

Schindler,DW (1977) Evolution of phosphorus limitation in lakes. *Science* 195:260-262.

Schindler,DW, Hesslein,RW, Turner,MA (1987) Exchange of nutrients between sediments and water after 15 years of experimental eutrophication. *Can. J. Fish. and Aquat. Sci.* 44:26-33.

Schlosser,IJ (1991) Stream fish ecology: a landscape perspective. *BioScience* 41:704-712.

Shaver,G (1998) A history of research. In Walker,DW (ed), *A Geobotanical Atlas of the Toolik Lake and Kuparuk River Region, Alaska*. This atlas is online at <http://www.Colorado.Edu/INSTAAR/TEAML/atlas/chapters/regdesc/history.html>

Shaver,GR (1996) Integrated ecosystem research in northern Alaska, 1947-1994. *In* Reynolds,J, Tenhunen,J (eds.) Landscape Function and Disturbance in Arctic Tundra. Springer-Verlag Ecological Studies Series Vol. 120. Springer-Verlag, Heidelberg, Germany.

Shaver,GR, Chapin,FS (1991) Production biomass relationships and element cycling in contrasting arctic vegetation types. *Ecological Monographs* 61(1)1-31.

Shaver,GR, Chapin,FS III (1995) Long-term responses to factorial NPK fertilizer treatment by Alaskan wet and moist tundra sedge species. *Ecography* 18:259-275.

Shaver,GR, Jonasson,S (In press) Productivity of Arctic Ecosystems. *In* Terrestrial Global Productivity. Mooney,H, Roy,J, Saugier,B (eds.) Academic Press, New York.

Shaver,GR, Laundre,JA (1997) Leaf exsertion, leaf elongation, and leaf senescence in *Eriophorum vaginatum* and *Carex bigelowii* in northern Alaska. *Global Change Biology*. Special issue on ITEX research. 3 suppl 1.

Shaver,GR; Chapin,FS,III; Gartner,BL (1986) Factors limiting growth and biomass accumulation in *Eriophoroum vaginatum* in Alaskan tussock tundra. *Journal of Ecology* 74:257-278.

Shaver,GR, Nadelhoffer,KJ, Giblin,AE (1990) Biogeochemical diversity and element transport in a heterogeneous landscape, the North Slope of Alaska,. *In* Turner,MG, Gardner,RH (eds.), *Quantitative Methods in Landscape Ecology*. Springer-Verlag, New York. p.105-126.

Shaver,GR, Billings,WD, Chapin,FS, Giblin,AE, Nadelhoffer,KJ, Oechel,WC, Rastetter,EB (1992) Global change and the carbon balance of arctic ecosystems. *Bioscience* 42:433-441.

Shaver,GR, Laundre,JA, Giblin,AE, Nadelhoffer,KJ (1996) Changes in vegetation biomass, primary production, and species composition along a riverside toposequence in arctic Alaska. *Arct. Alp. Res.* 28:363-379.

Shaver,GR, Johnson,LC, Cades,DH, Murray,G, Laundre,JA, Rastetter,EB, Nadelhoffer,KJ, Giblin,AE (1998) Biomass accumulation and CO₂ flux in three Alaskan wet sedge tundras: Responses to nutrients, temperature, and light. *Ecological Monogr.* 68:75-98.

Sollins,P, McCorison,FM (1981) Nitrogen and carbon solution chemistry of an old growth coniferous forest watershed before and after cutting. *Wat. Res. Res.* 17:1409-1418.

Steiglitz,M, Rind,D, Famiglietti,J, Rosenzweig,C (1997) An efficient approach to modeling the topographic control of surface hydrology for regional and global climate modeling. *Journal of Climate* Vol.10(1) 119-137.

Sugai,SF, Kipphut,GW (1992) The influence of light and nutrient addition upon the sediment chemistry of iron in an arctic lake. *Hydrobiologia* 240:91-1011.

Swank,WT, Crossley,DA (1988) *Forest Hydrology and Ecology at Coweeta*. Ecological Studies Series. Volume 66. Springer-Verlag, New York.

The Stream Bryophyte Group (In press) Roles of bryophytes in stream ecosystems. *Journal of the North American Benthological Society*, in press.

Townsend,CR (1996) Concepts in river ecology: pattern and process in the catchment hierarchy. *Archiv fur Hydrobiologie Supplement* 113 Large Rivers 10:3-21.

Turner,MG, Dale,VH (1990) Modeling landscape disturbance. *In* Turner,MG, Gardner,RG (eds.), *Quantitative Methods in Landscape Ecology*. Springer-Verlag. 536

Vannote,RL, Minshell,GM, Cummins,K, Sedell,J, Cushing,C (1980) The river continuum concept. *Can. J. Fish. Aquat. Sci.* 37:130-137.

Wallace,JB, Eggert,SL, Meyers,JL, Webster,JR (1997) Multiple trophic levels of a forest-stream linked to terrestrial litter inputs. *Science* 277:102-104.

Whalen,SC, Cornwell,JC (1985) Nitrogen, phosphorus and organic carbon cycling in an arctic lake. *Can. J. Fish. Aquat. Sci.* 42:797-808.

Williams,M, Rastetter,EB, Fernandes,DN, Goulden,ML, Shaver,GR (1997) Predicting gross primary productivity in terrestrial ecosystems. *Ecological Applications* 7:882-894.

Wilson,R, Allen-Gil,S, Griffin,D, Landers,D (1995) Organochlorine contaminants in fish from an arctic lake in Alaska, USA. *In* Nriagu,JO (ed.), *The Science of the Total Environment*, Elsevier. Vols. 160, 161:323-511.

WootenJT, Parker,MS, Power,ME (1996) Effects of disturbance on river food webs. *Science* 273:1558-1561.

Zimov,SA, Voropaev,YV, Semiletov,IP, Davidov,SP, Prosiannikov,SF, Chapin,FS III, Chapin,MC, Trumbore,S, Tyler,S (In press) North Siberian lakes: A methane source fueled by Pleistocene carbon. *Science*.

Table 1. Experimental Designs for Terrestrial Research of the Arctic LTER Project.

Location	Year Started	Ecosystem Type	Treatments
Toolik Lake (main LTER site)	1980	Moist Tussock	Control, N+P Fert
	1988	Moist Tussock Wet Sedge Dry Heath Riparian Shrub	Control, N, P, N+P, Greenhouse, Shade, Greenhouse+N+P, Shade +N+P
	1989	Moist Tussock Dry Heath	Control-Herbivore Exclosure
	1996	Moist Tussock Dry Heath	Control-Herbivore Exclosure, N+P-Herbivore Exclosure+N+P
	1997	Nonacidic Tussock Nonacidic Nontussock	Control, N, P, N+P, Greenhouse, Greenhouse+N+P
Sag River Toposequence	1984	Moist Tussock Dry Heath Snowbed Equisetum/Forb Wet Sedge Riparian Shrub	Control, N, P, N+P, C enrichment (starch, sawdust), Lime

Table 2. Summary of LTER lake monitoring, surveys, manipulations, and modeling.

MONITOR	SURVEY	MANIPULATE	MODEL
Previously fertilized lakes N-1 and N-2	Lakes of different ages for nutrient exchange with sediment	Add nutrients to lakes S-6 and S-7	Model response of S-6 and S-7
Toolik Lake to measure annual variation	Lakes for presence of char, lake trout, or both	Reciprocal additions of char and lake trout	Bioenergetic model of lake trout response to temperature changes
Previously predator-manipulated lakes with added grayling, added sculpin, slow removal of lake trout, added <i>Heterocope</i>	Lakes along N-S transect for different mixing patterns and health of lake trout populations	Add <i>Heterocope</i> to ponds	Lake thermal properties and biotic response to nutrients

Table 3. Export in g C m⁻² of basin y⁻¹ of DOC (dissolved organic C), DIC (dissolved inorganic C), and POC (particulate organic C) in the Kuparuk River to the Arctic Ocean, and loss of CO₂ and CH₄ (as g CH₄) to the atmosphere from surface waters.

Loss of C from the Kuparuk Basin from Surface Waters

<i>Year</i>	DOC	DIC	POC	CO₂	CH₄	<i>Total</i>
1994	0.6	1.4	0.03	1.4	0.13	3.6
1995	1.1	1.4	0.05	1.1	0.06	3.7
1996	1.3	1.2	0.33	1.0	0.08	3.9
<i>Mean 94-96</i>	<i>1.0</i>	<i>1.3</i>	<i>0.14</i>	<i>1.2</i>	<i>0.09</i>	<i>3.73</i>

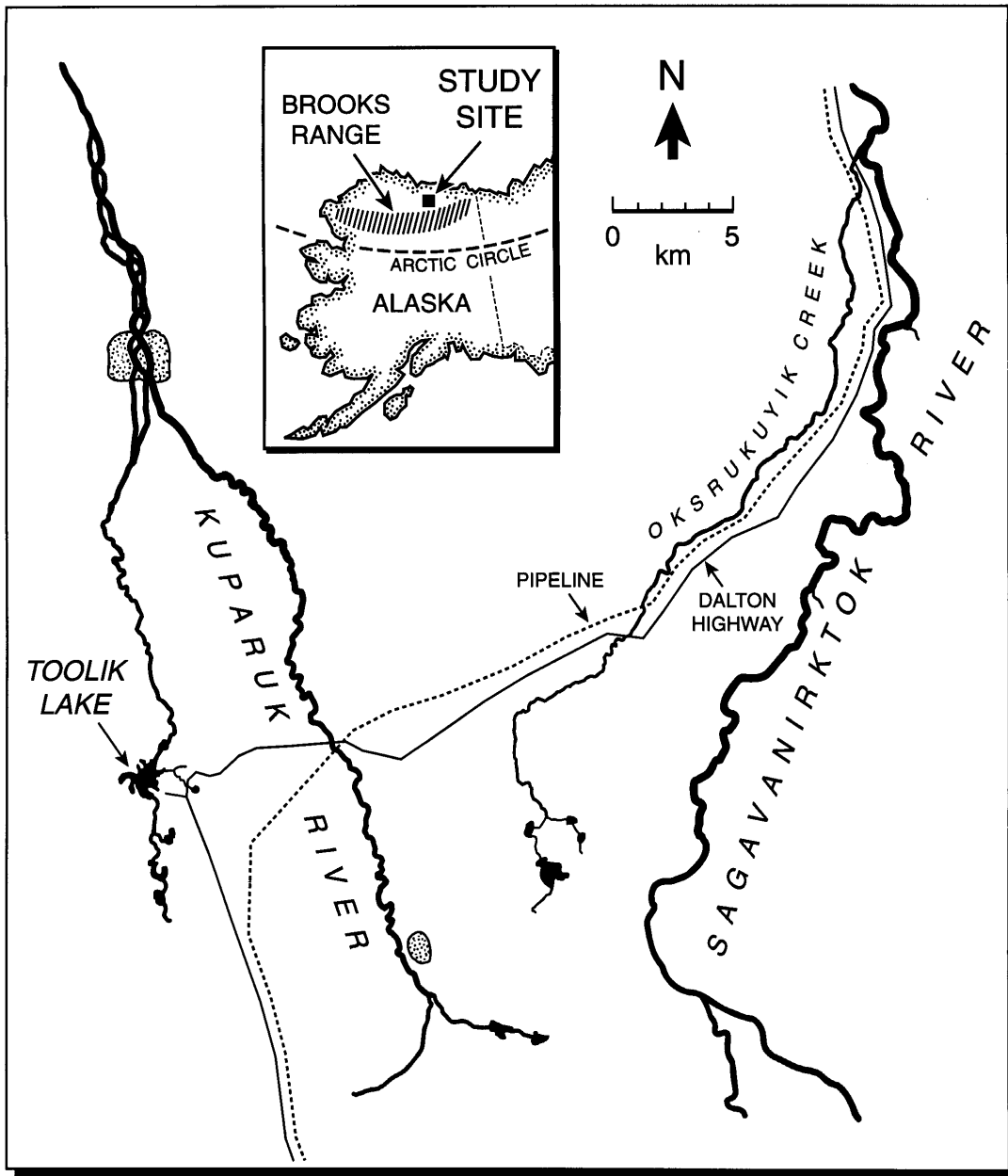

Fig. 1. Location of the Arctic LTER site in Alaska along the Dalton Highway that services the TransAlaska pipeline. The site is the tundra, streams, and lakes in the Toolik lake drainage basin, in the upper Kuparuk River drainage basin above the junction with the Toolik lake outlet river, and the drainage basin of Oksrukuyik Creek (south of the Dalton Highway). Stippled areas indicate springs.

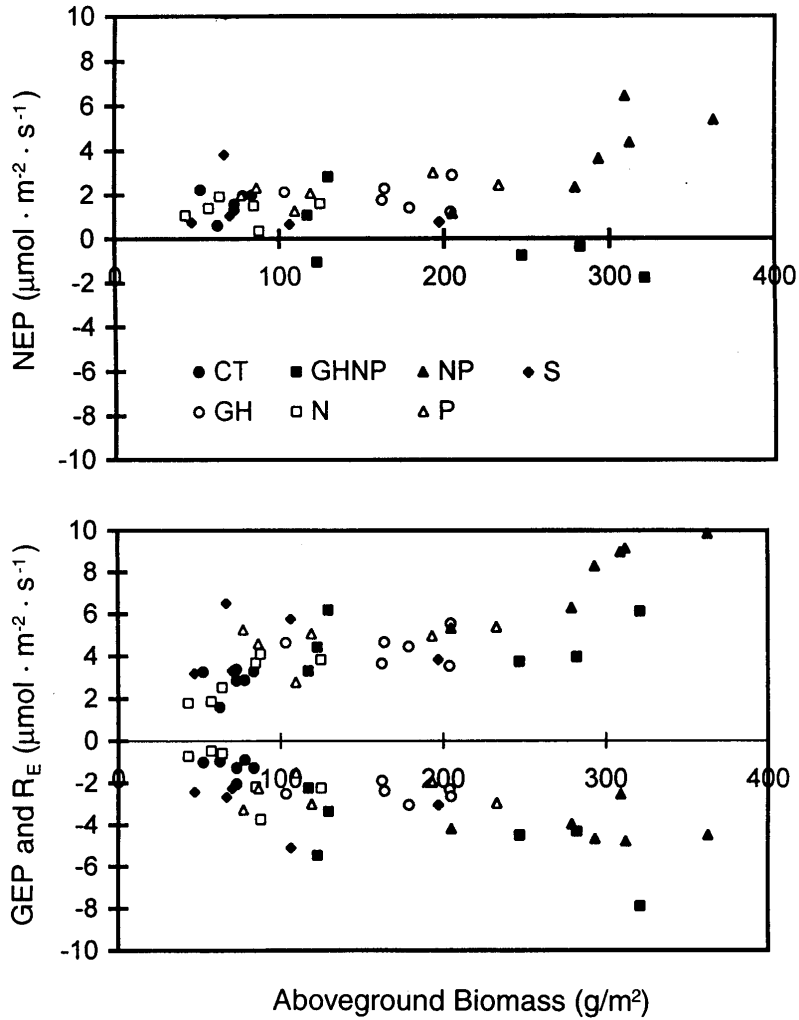

Fig. 2. NEP, GEP, and R_E versus total aboveground biomass in the experimental plots at the Toolik Inlet and Outlet sites. Units are micromoles $\text{CO}_2 \text{ m}^{-2} \text{ ground s}^{-1}$ and g m^{-2} . Treatments indicated as: CT=control; N=N-fertilized; P=P-fertilized; NP=N+P fertilized; GH=greenhouse; GHNP=greenhouse+N+P; S=shade.

KUPARUK RIVER

OKSRUKUYIK CREEK

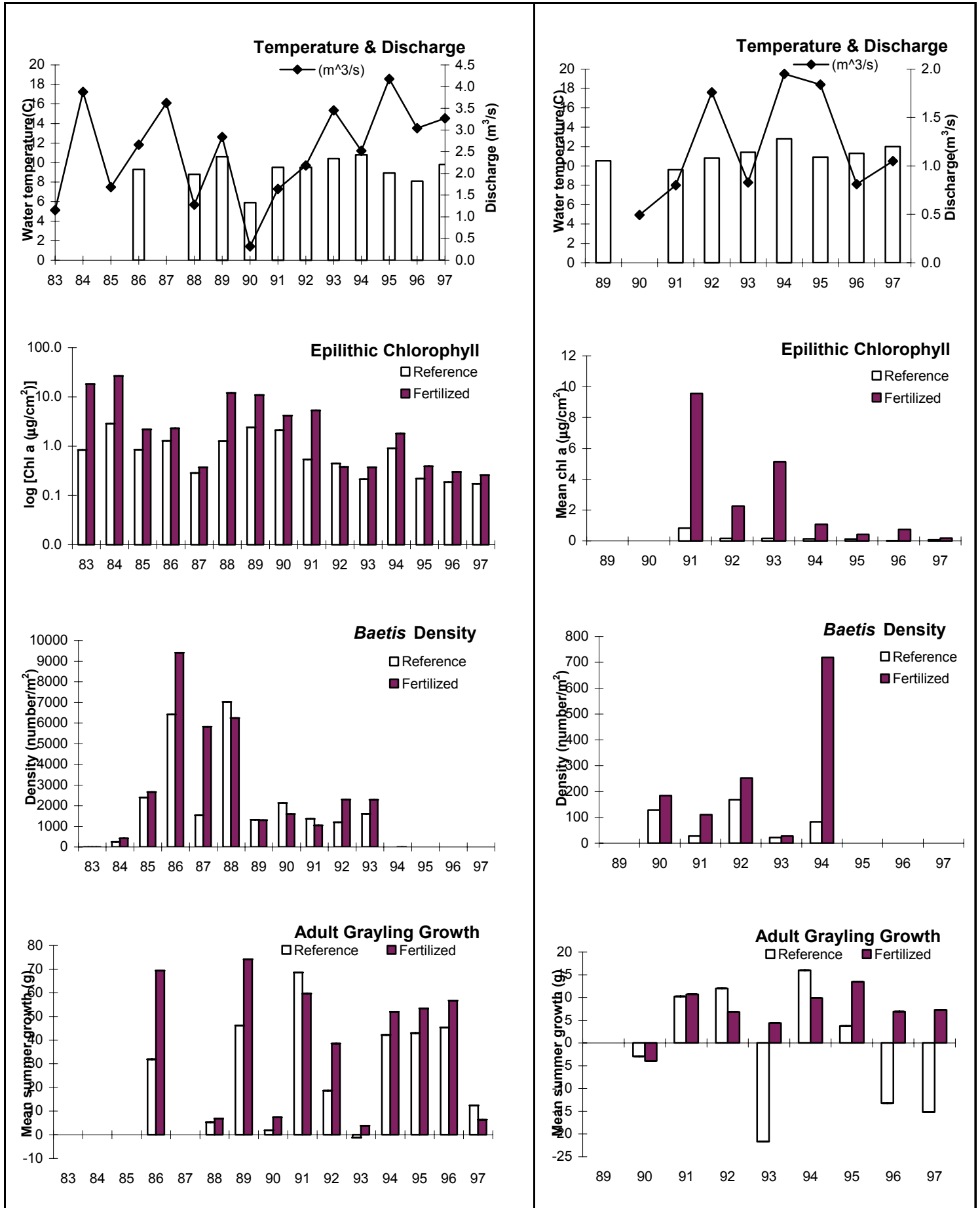

Fig. 3. Long-term record of the response of the Kuparuk River and Oksrukuyik Creek to fertilization. In both rivers, fertilization stimulated algal biomass, insect abundance (here illustrated by mayflies *Baetis*), and fish growth (Arctic grayling).

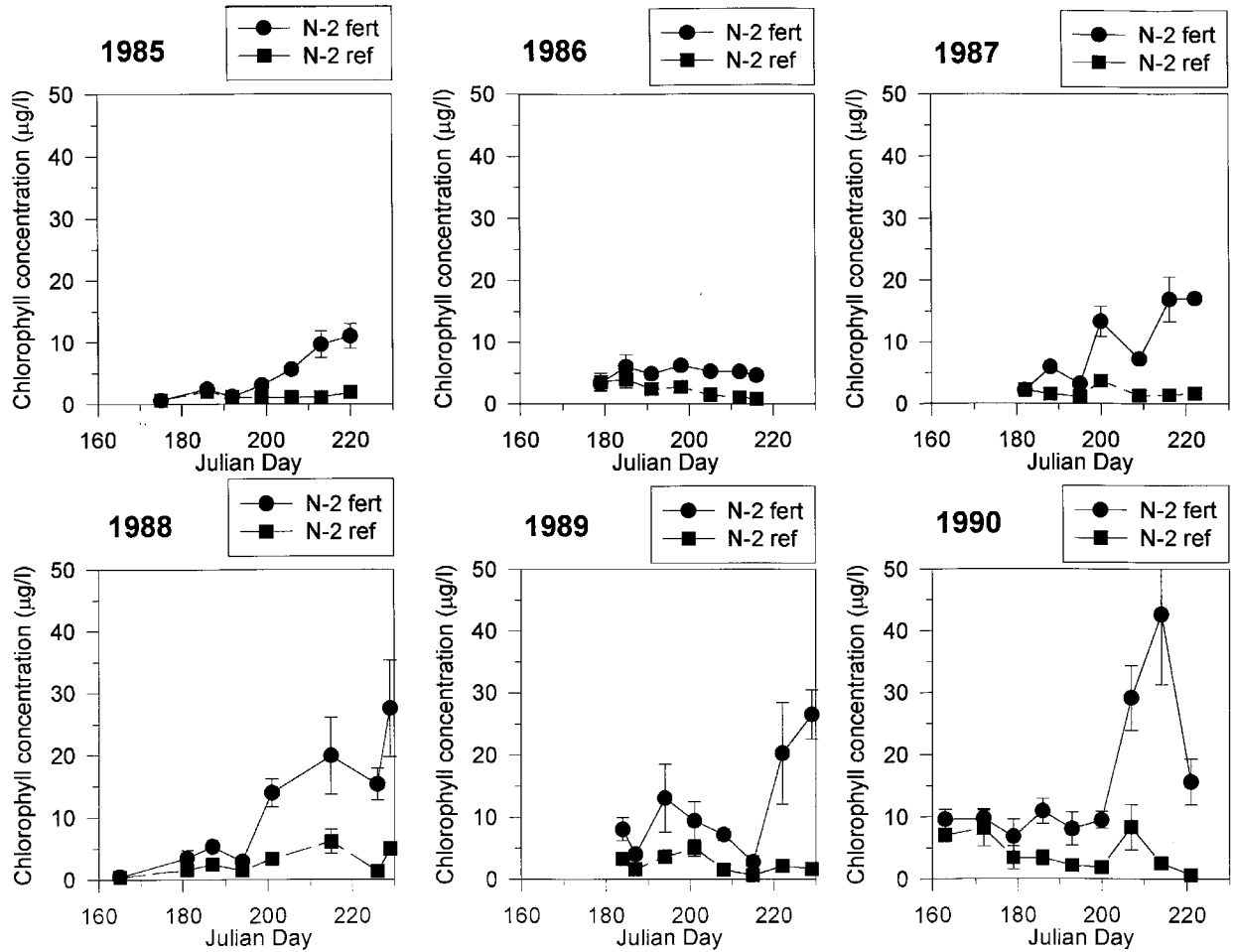

Fig. 4. The response of phytoplankton, as measured by the chlorophyll concentration, to the addition of nutrients to half of a divided lake (N-2). Fertilization began in 1985 and continued through the summer of 1990. The two sides are designated fert (fertilization) and ref (reference). Because of sediment absorption of phosphorus, there was no carryover of phosphorus in the water column from one year to the next until the last two years of the addition.

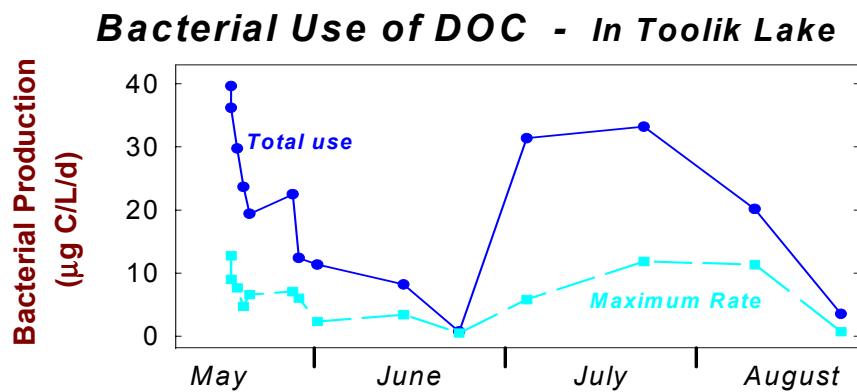
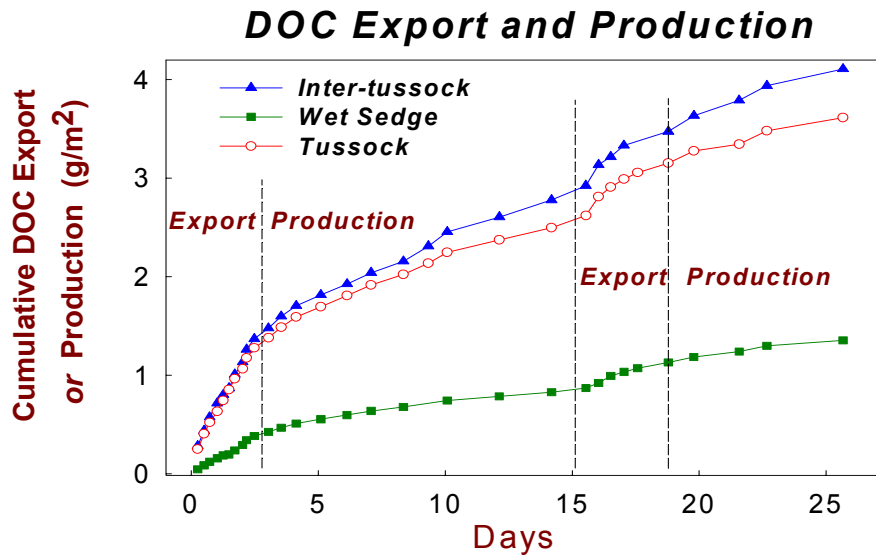

Fig. 5. DOC export and production from an experiment where intact plant-soil microcosms underwent two cycles of flushing with water to simulate rain events. The flushing periods (export) measure the ability of these different vegetation types to export DOC, while the periods in between flushing (production) measure the accumulation of DOC in the soil waters. Both export and production are measured as the cumulative mass of DOC per surface area.

Fig. 6. Bacterial use of DOC in Toolik Lake as indicated by the bacterial production during (*Maximum Rate*) and at the end (*Total Use*) of 14 ten-day bioassay experiments using lake bacteria that were fed water from the inlet to the lake. The concentration of DOC (not shown) was similar during spring runoff in May and a summer storm in July when bacterial use of DOC was highest.

Generic Diagram

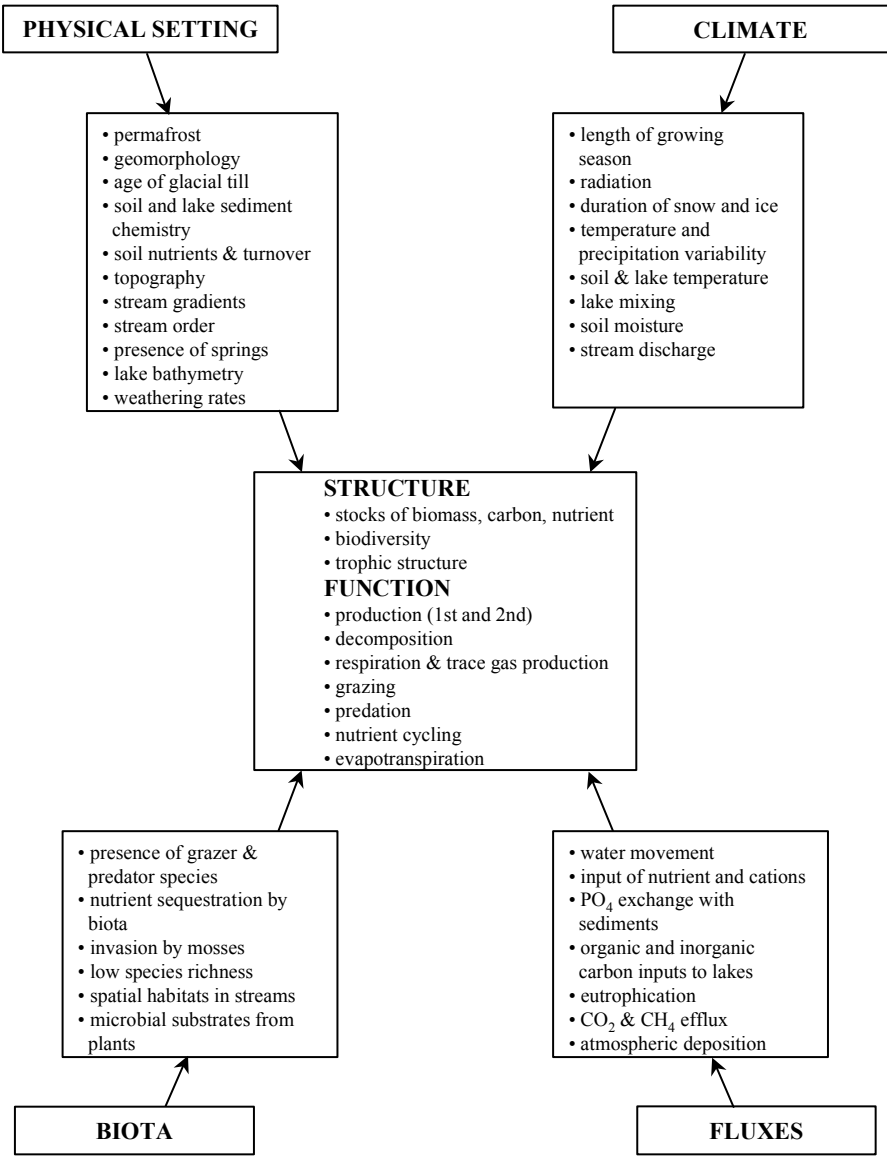

Fig. 7. Generic conceptual framework of controls of ecosystem structure and function for Toolik ecosystems.

Terrestrial

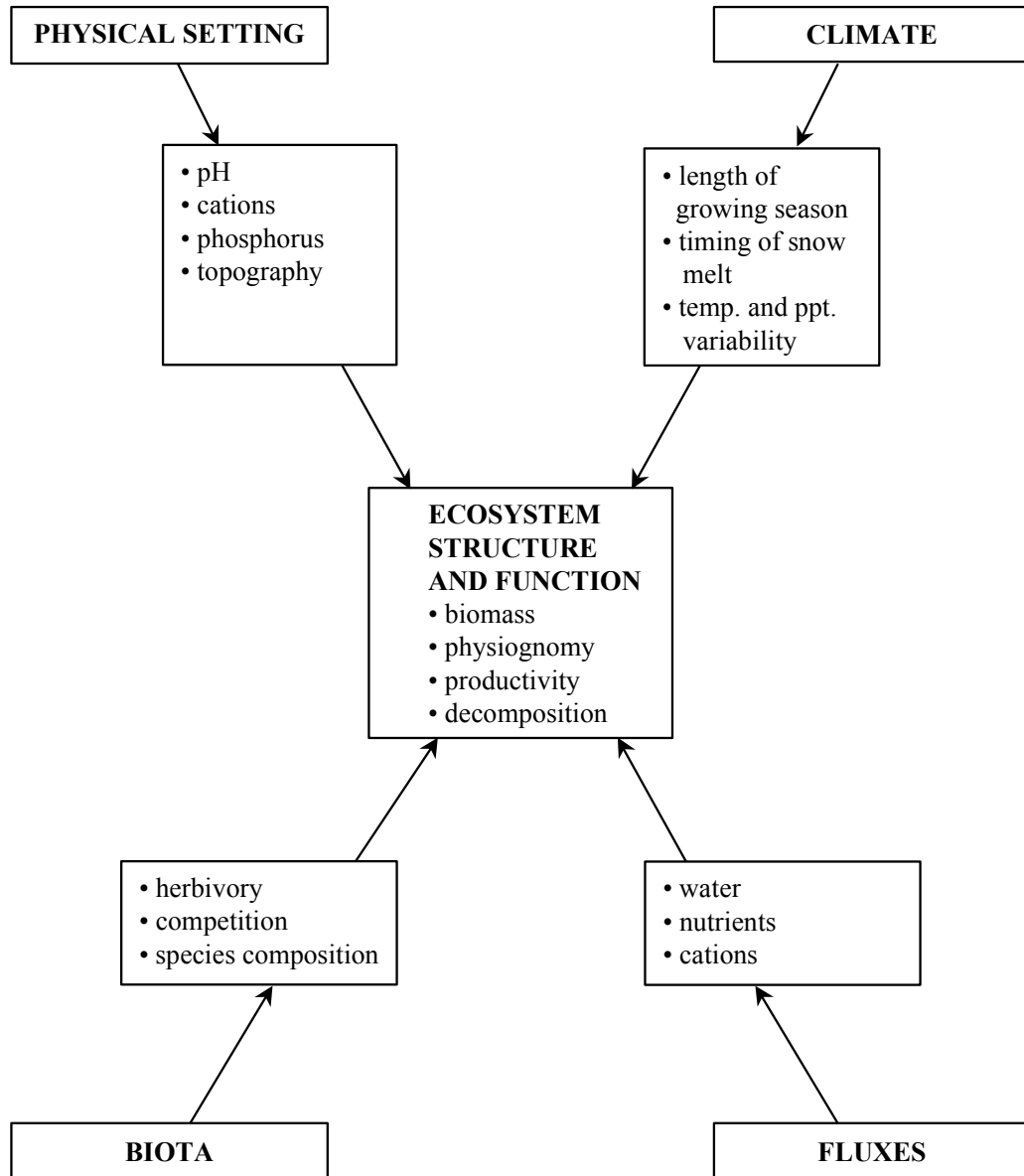

Fig. 9. Conceptual framework of controls of ecosystem structure and function for terrestrial tundra ecosystems at Toolik.

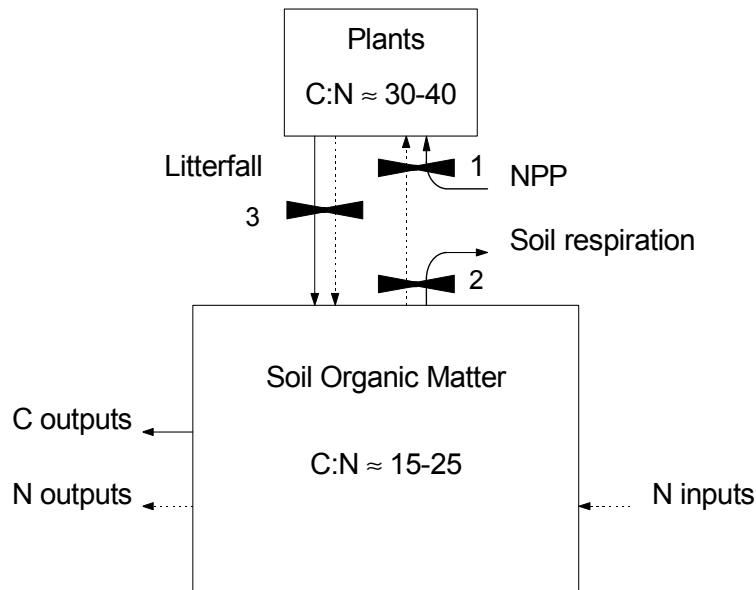

Fig. 10. The Simple Arctic Model (SAM; Shaver et al. 1992) of element interactions, using C and N as an example. This model contains two major organic matter pools in the ecosystem (i.e., plants and soil). Carbon fluxes into and out of these pools are indicated by solid lines and N by dashed lines. Bow ties show links between C and N fluxes. Bow tie #1 implies that net C uptake by plants (net primary production, NPP) is constrained by plant N uptake capacity, and vice versa. We suggest that in nutrient-limited systems, such as tundras, essentially all of plant nutrient supply comes from the mineralization of soil organic matter (including litter) and that N mineralization is linked to soil C respiration. (Dissolved C losses indicated by the arrow at lower left, are small relative to gaseous exchanges.) Thus, at least in a proximate sense, the overall C balance of such ecosystems (i.e., the difference between NPP and soil respiration) is largely determined by C gains associated with plant N uptake, balanced against C losses associated with N mineralization.

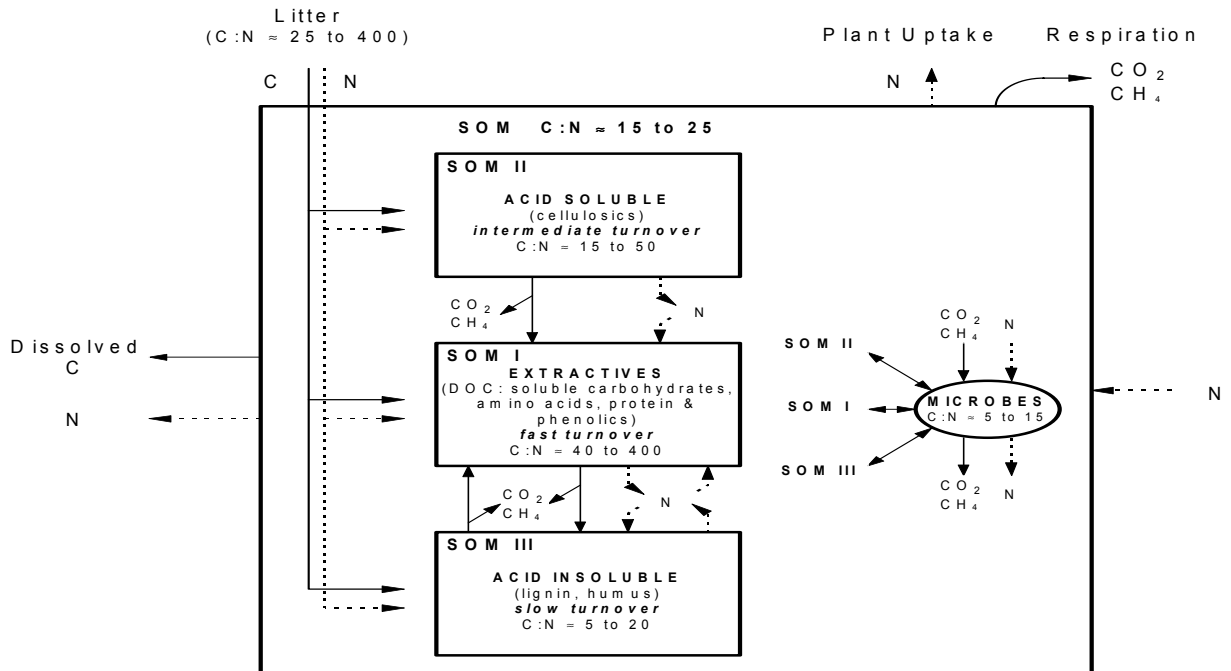

Fig. 11. The Model of Arctic Decomposition (MAD), in which a new level of detail is added to the “Soil Organic Matter” (SOM) box of SAM (Fig. 10). Inputs and outputs to SOM are the same as in the SAM model with solid lines representing C fluxes and dashed lines representing N fluxes. The three SOM pools (I, II and III) are operationally defined as extractives, acid soluble, and acid insoluble and are hypothesized as having different turnover times and C:N ratios. Inputs to these pools include soluble organic matter, cellulose and lignin from plant litter and microbially mediated fluxes of C and N from other SOM pools. Microbial by-products also serve as inputs to all three SOM pools. Respiratory losses of CO₂ and/or CH₄ accompany C transfers among SOM pools. In addition, dissolved inorganic carbon (DIC), and dissolved organic carbon (DOC) can be lost as leachate. Mineralized N and dissolved organic N (DON) released from individual pools can be assimilated by microbes, incorporated into other SOM pools, taken up by plants or leached from soils. Small amounts (not show) can be exported as nitrous oxides formed during nitrification or denitrification.

Streams

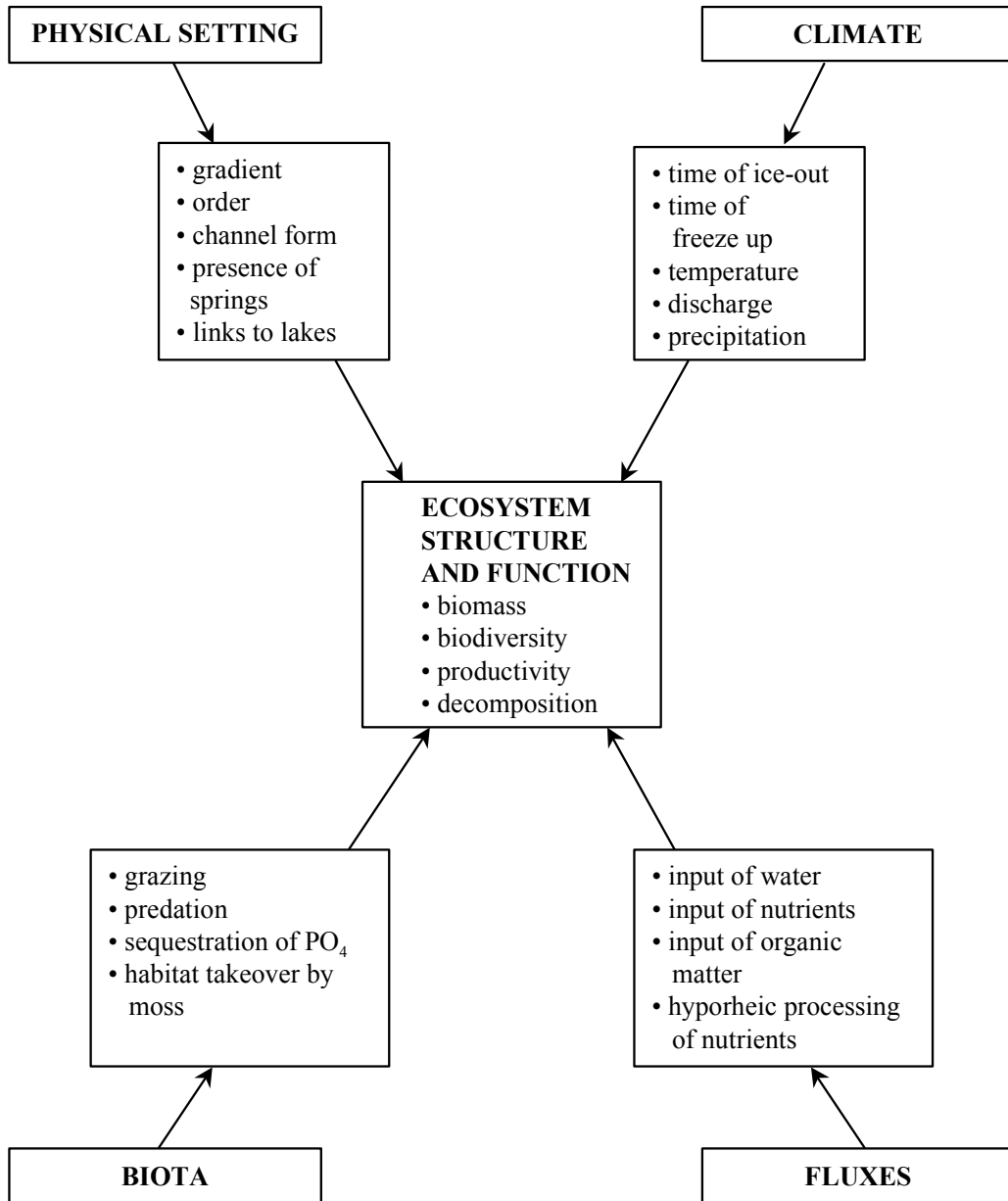

Fig. 12. Conceptual framework of controls of ecosystem structure and function for stream ecosystems at Toolik.

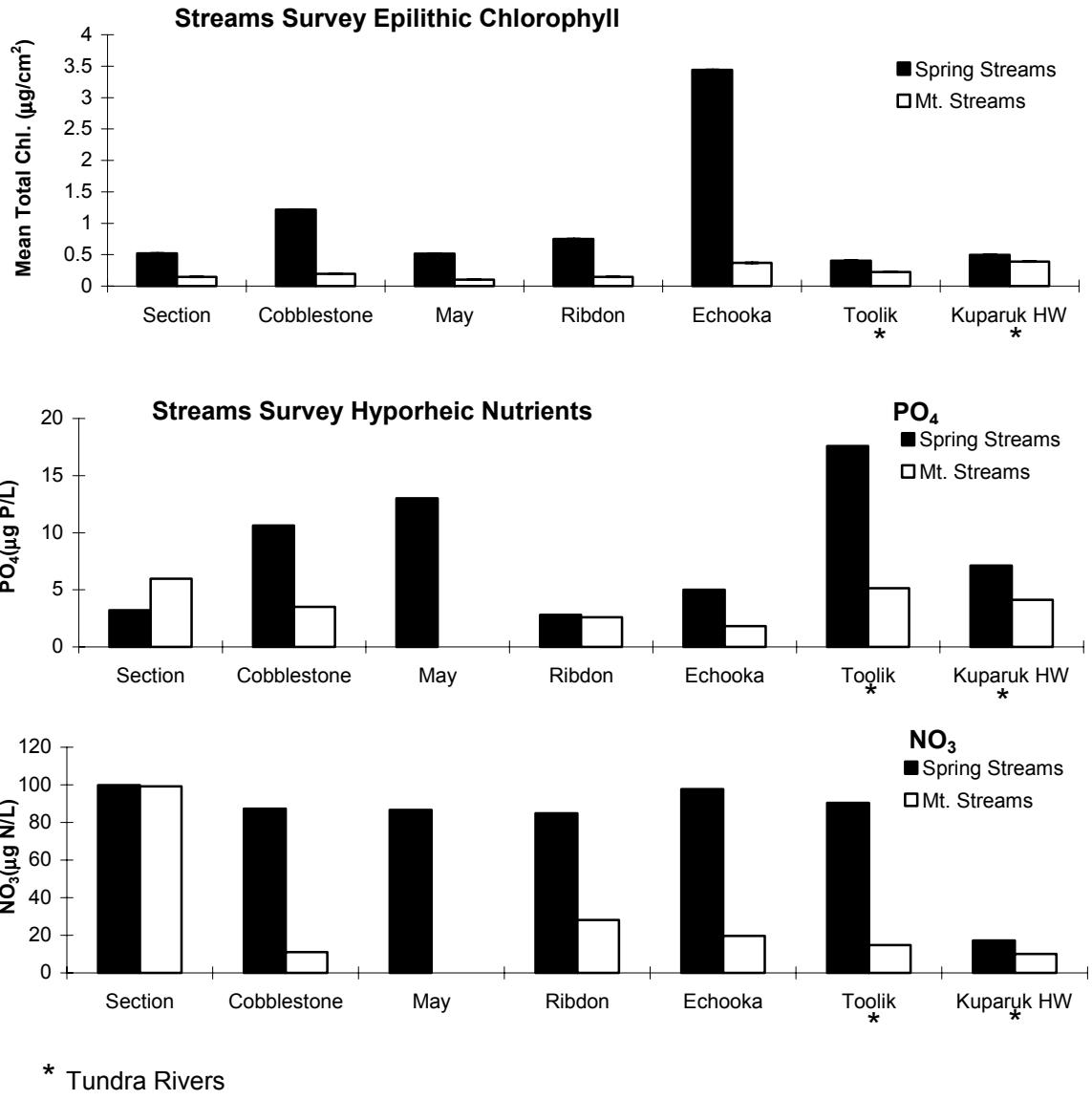

Figure 13 . Comparisons of the standing stocks of epilithic chlorophyll, hyporheic phosphate and hyporheic nitrate between perennial springs versus alpine and tundra streams.

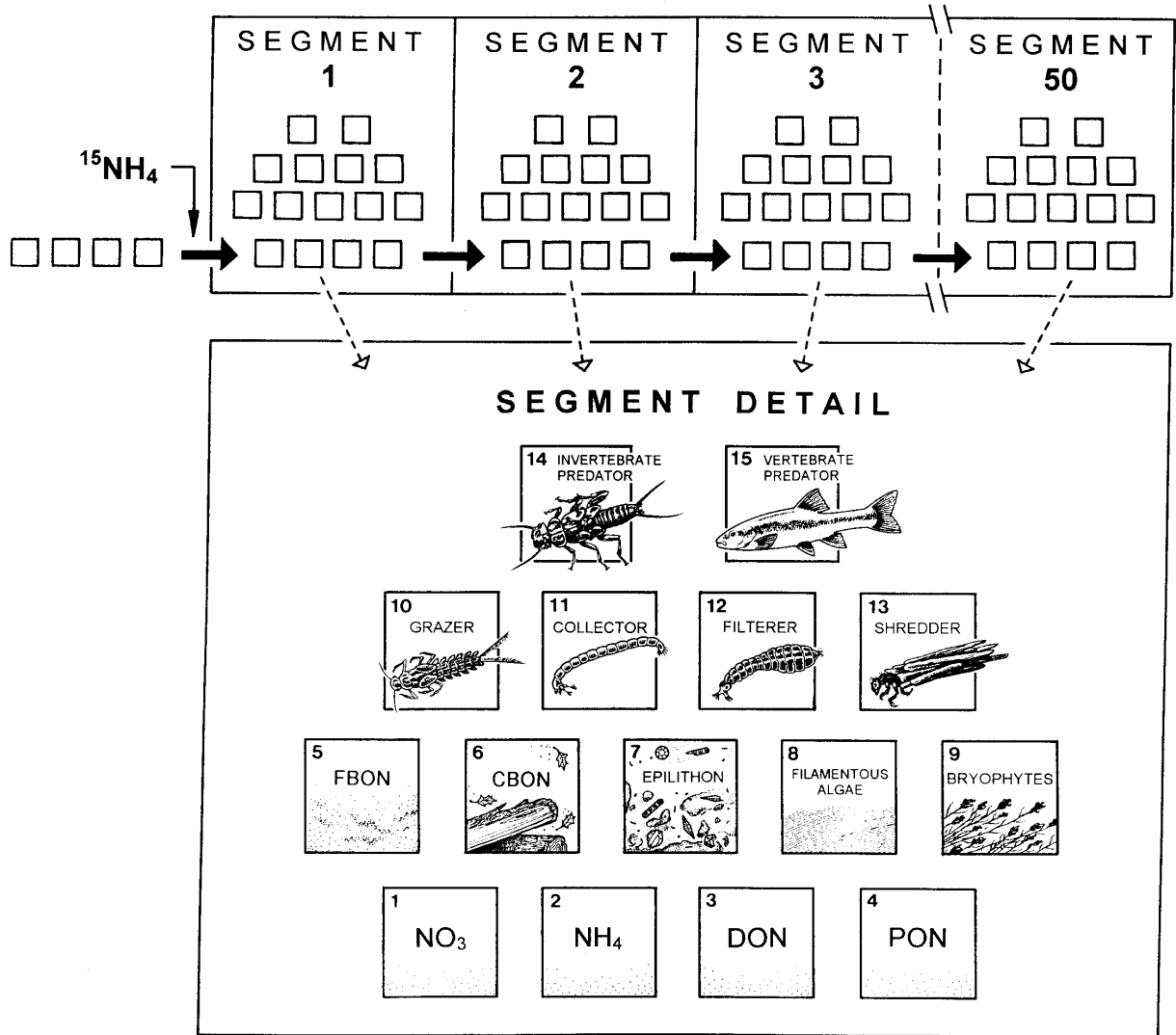

Fig. 14. Schematic diagram of river reach model used to calculate N transformations, transport and retention. Each reach of the river has a community model embedded within it.

Lakes

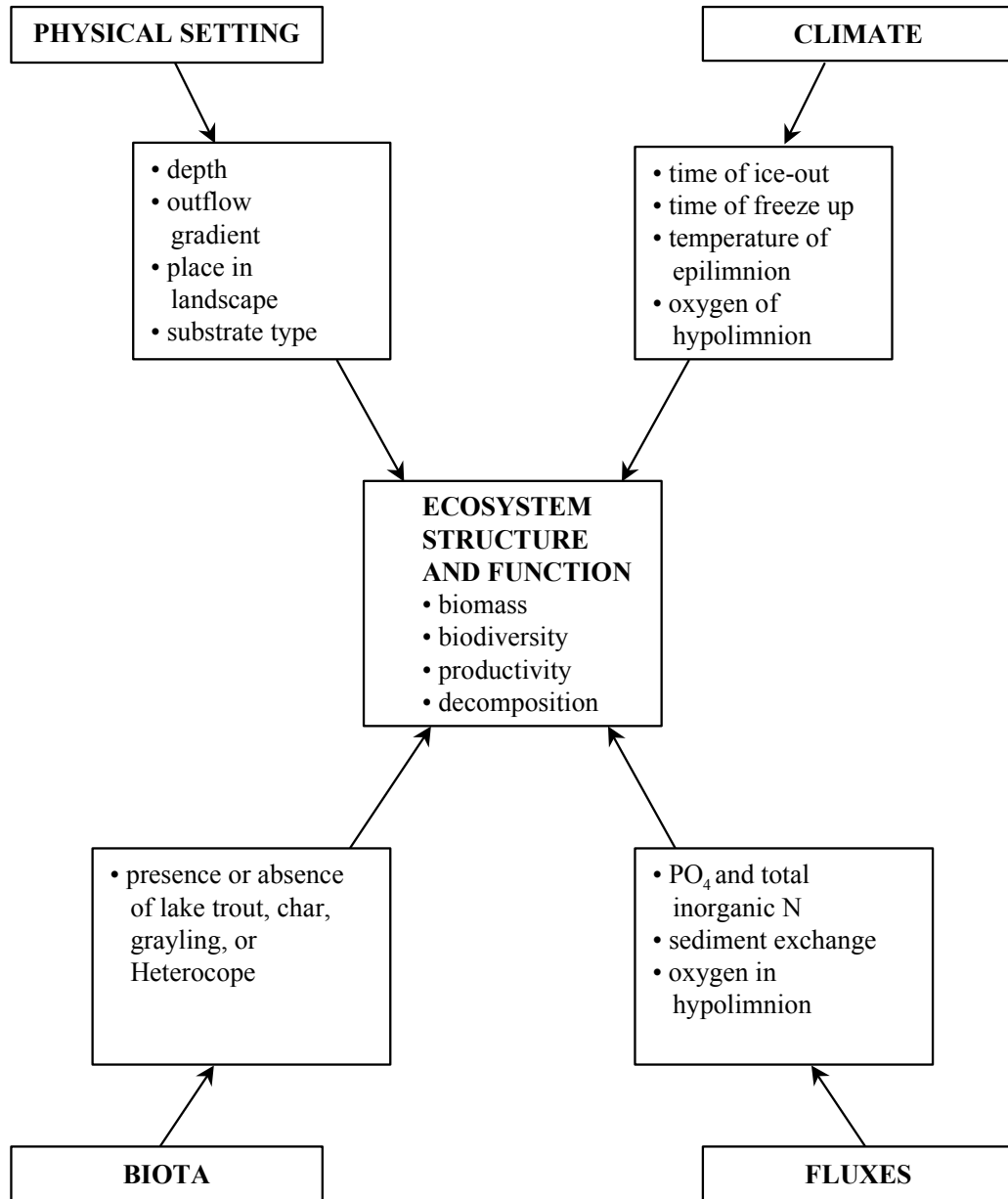

Fig. 15. Conceptual framework of controls of ecosystem structure and function for lake ecosystems at Toolik.

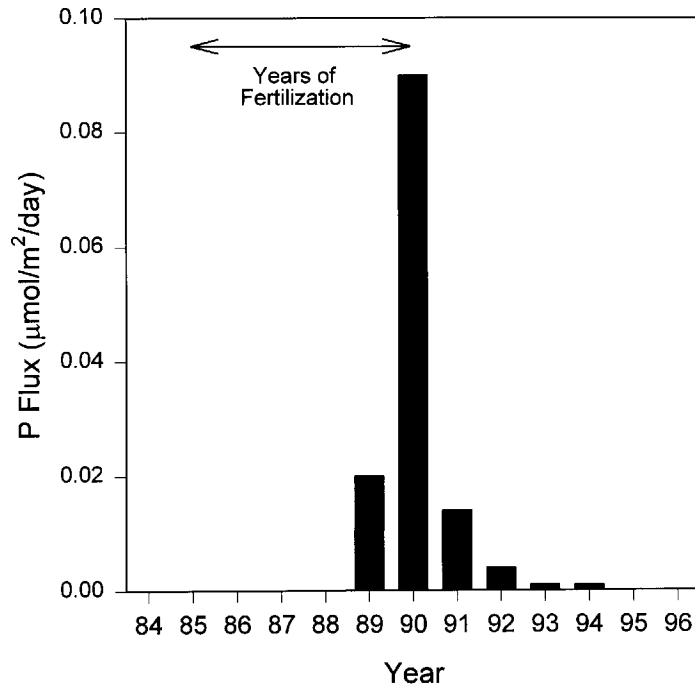

Fig. 16. The mean flux of phosphorus from sediments to the overlying water in Lake N-2. This lake was fertilized each summer from 1985 through 1990 but iron oxides in the sediment removed and held most of the phosphorus in the water column until the last two years of fertilization.

Chironomid Response To Sculpin Addition in Lake E1

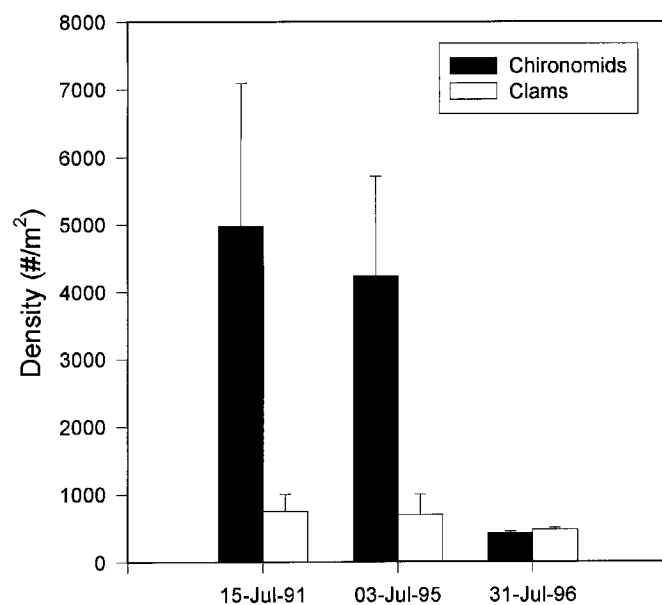

Fig. 17. The response of the numbers of chironomids and small clams to the addition of sculpin to a previous fishless lake (E-1).

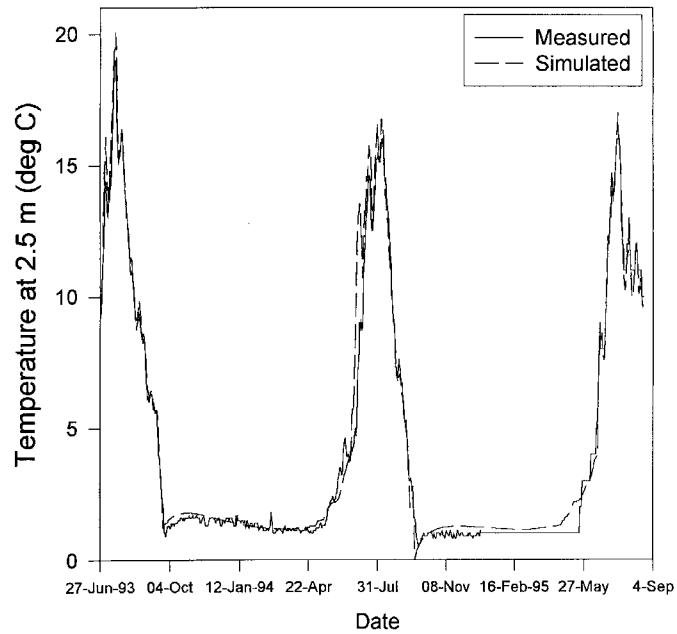

Fig. 18. The measured and simulated temperature at 2.5 m depth in Toolik Lake, 1993-1995. Input to the model was Toolik weather station daily climate data.

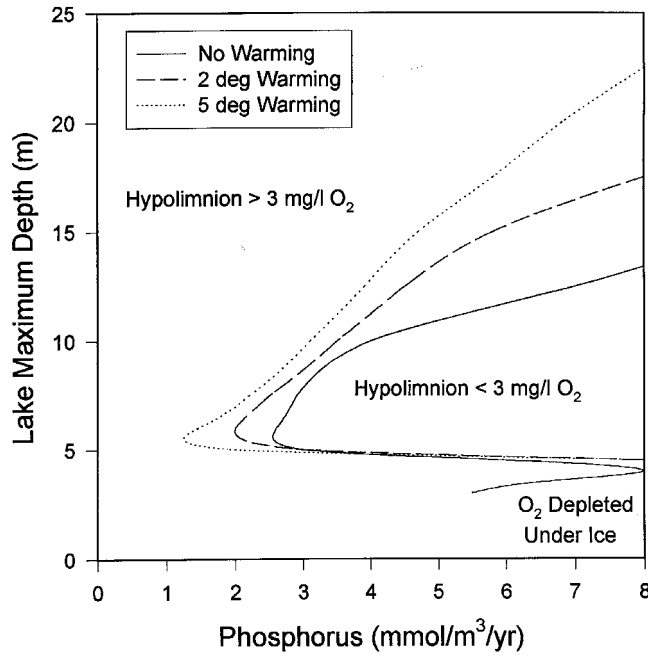
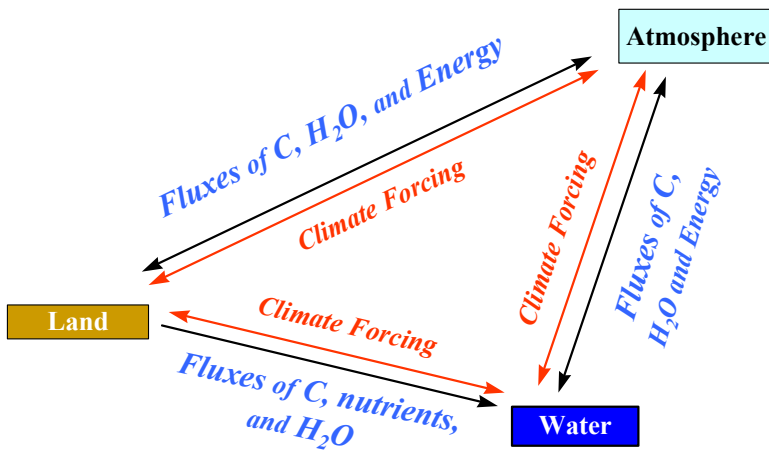
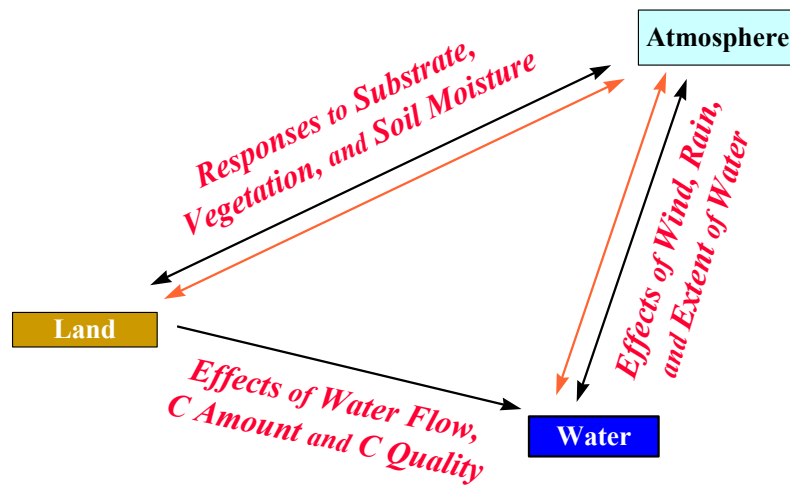

Fig. 19. Results from runs of the Arctic Lake Model for June 1993 through August 1994. The results show the critical combinations of the maximum depth of the lake and the phosphorus loading that produces a hypolimnion with less than 3 mg O₂ per liter. This is a lower threshold for lake trout survival. The area of low oxygen is increased with 2° and 5° C increases in the climate data.



(A) Conceptual Model



(B) Important Controls on Interactions

Fig. 20. The Physical-Biogeochemical Arctic System.

Land-Water

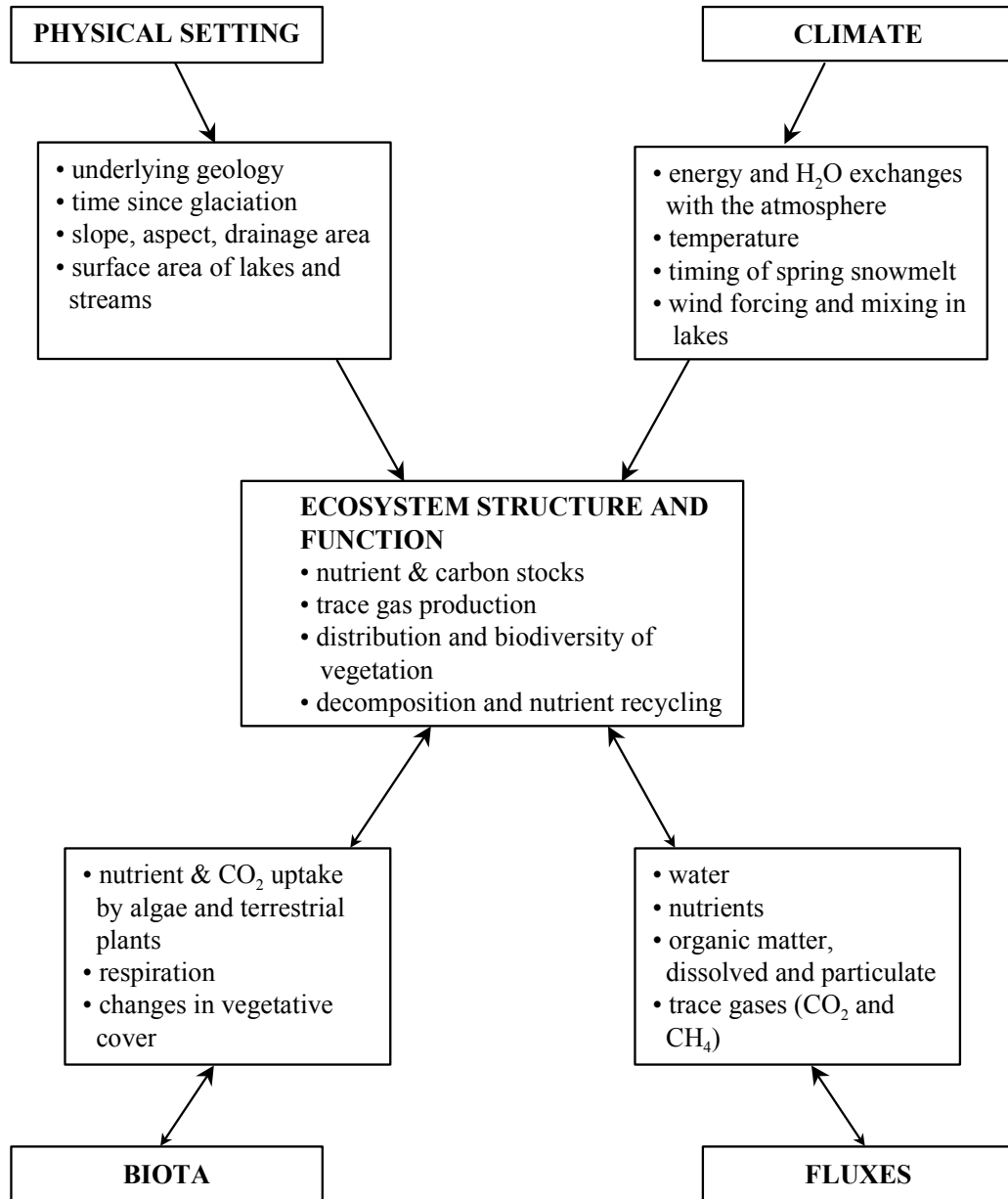

Fig. 21. Conceptual framework of controls of ecosystem structure and function for land-water interactions at Toolik.

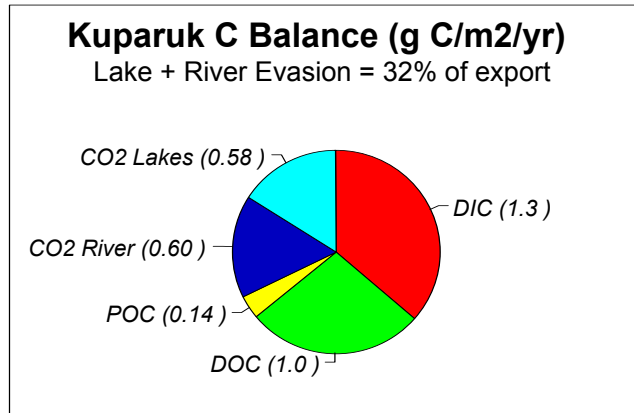

Fig. 22. Average proportions of C loss from the Kuparuk Basin from 1994 to 1996 in g C m⁻² of basin per yr. DOC, DIC, and POC are exported in river flow to the Arctic Ocean, while CO₂ from lakes and rivers is released directly to the atmosphere. This release accounts for ~32% of the total carbon lost per m² of basin from aquatic systems.

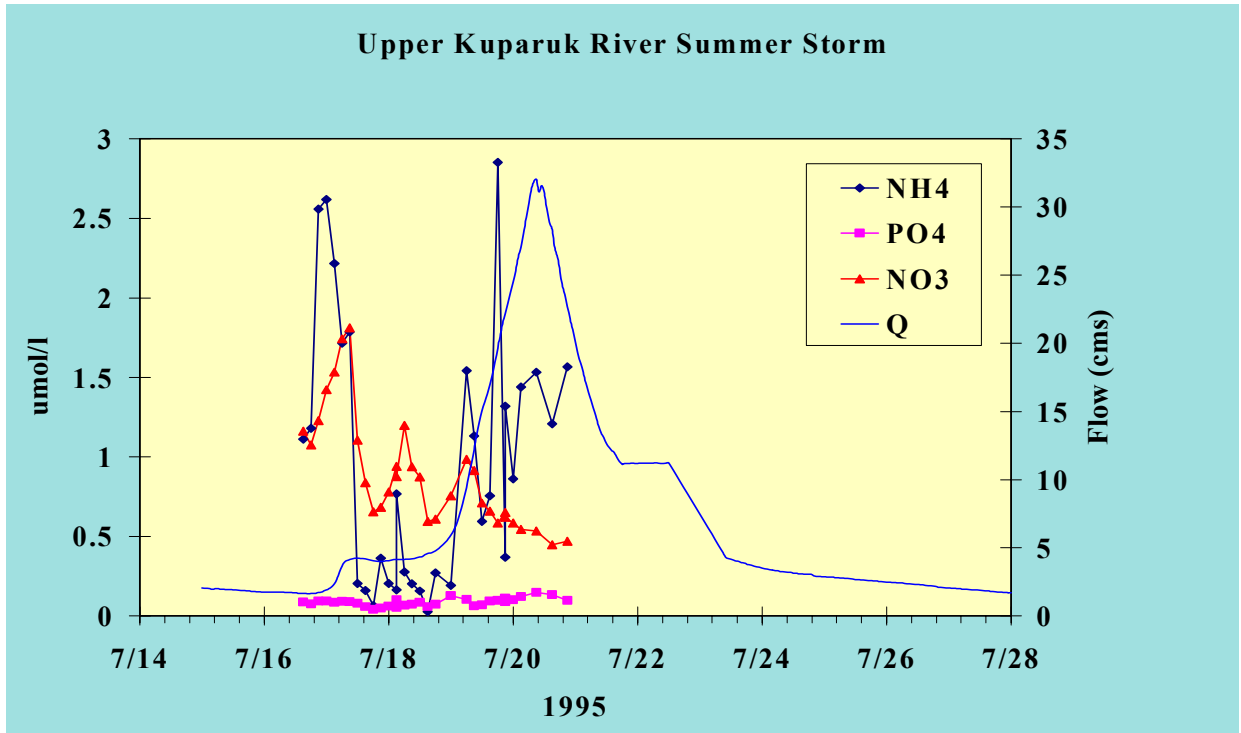

Fig. 23. Relationship of nutrient concentrations ($\mu\text{mol/L}$) to discharge in the upper Kugaruk basin.

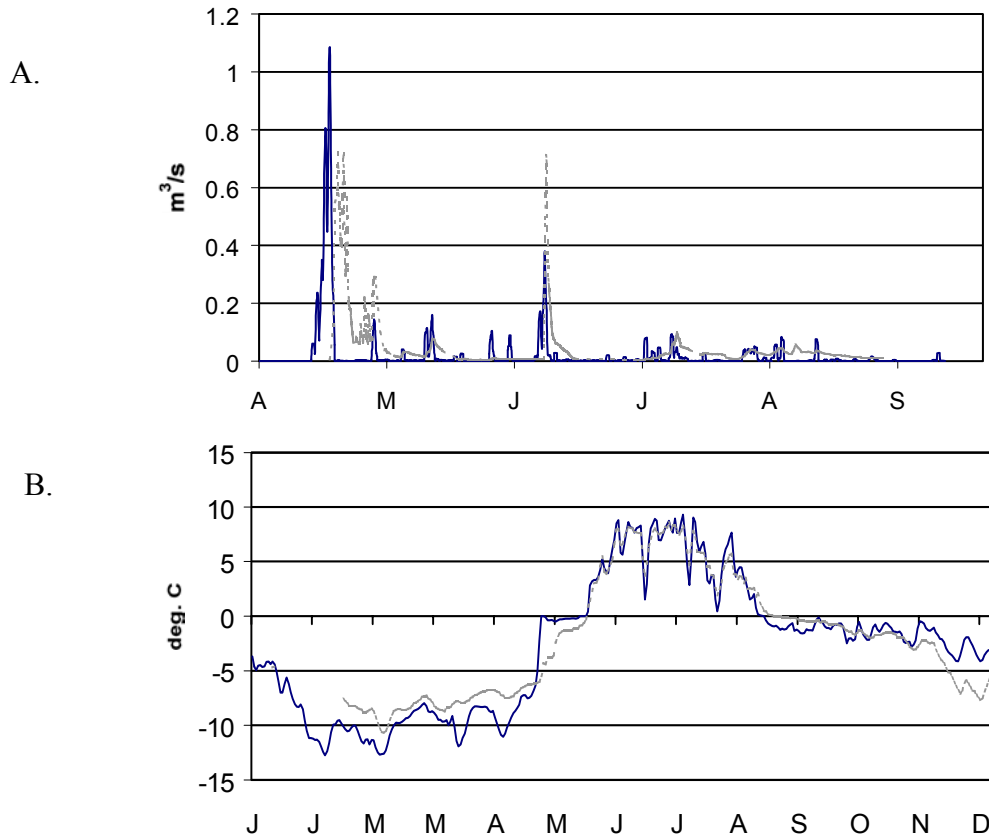

Fig. 24. A. The 1993 runoff at Innavait Creek. The solid line is model output from a modified TOPMODEL. The dotted line is discharge measured by the Kane-Hinzman ARCSS project.

B. The 1992 modeled (solid line) and measured soil temperatures at 14-15 cm depth in Innavait Creek watershed. Data from Kane-Hinzman ARCSS project. The model was developed by M. Stieglitz (Stieglitz et al. 1997).

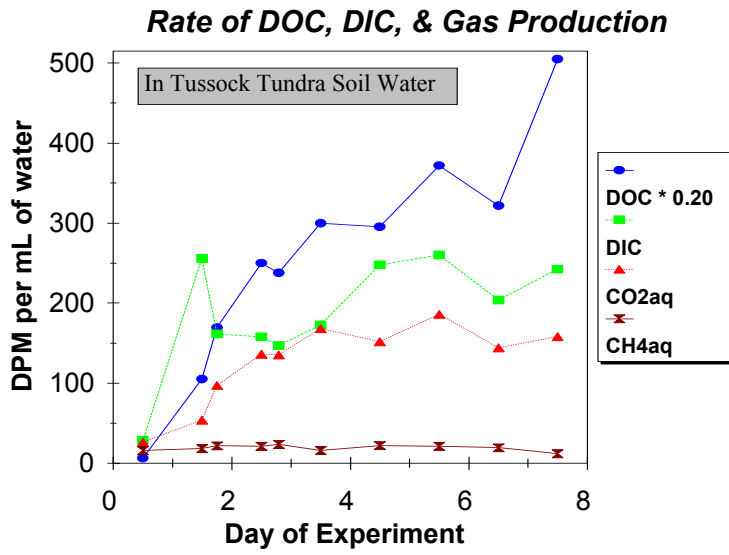

Fig. 25. The increase in ^{14}C -labeled materials in DOC, DIC, CO_2 , and CH_4 of soil water after incubation of tussock plants with $^{14}\text{CO}_2$.